

## PRIUS

### Motor driven diaphragm metering pump

Motor-driven diaphragm dosing pump, mechanical actuated, PRIUS combines efficiency and chemical resistance to a wide capacity range for an extensive number of applications.

ATEX

CE Ex II 2 G c IIB T3, T4

CE Ex II 2 D IIIC T125°C, resp T135°C

- Three phase motor power supply
- Spring return mechanism
- Manual degassing valve



### Identification code

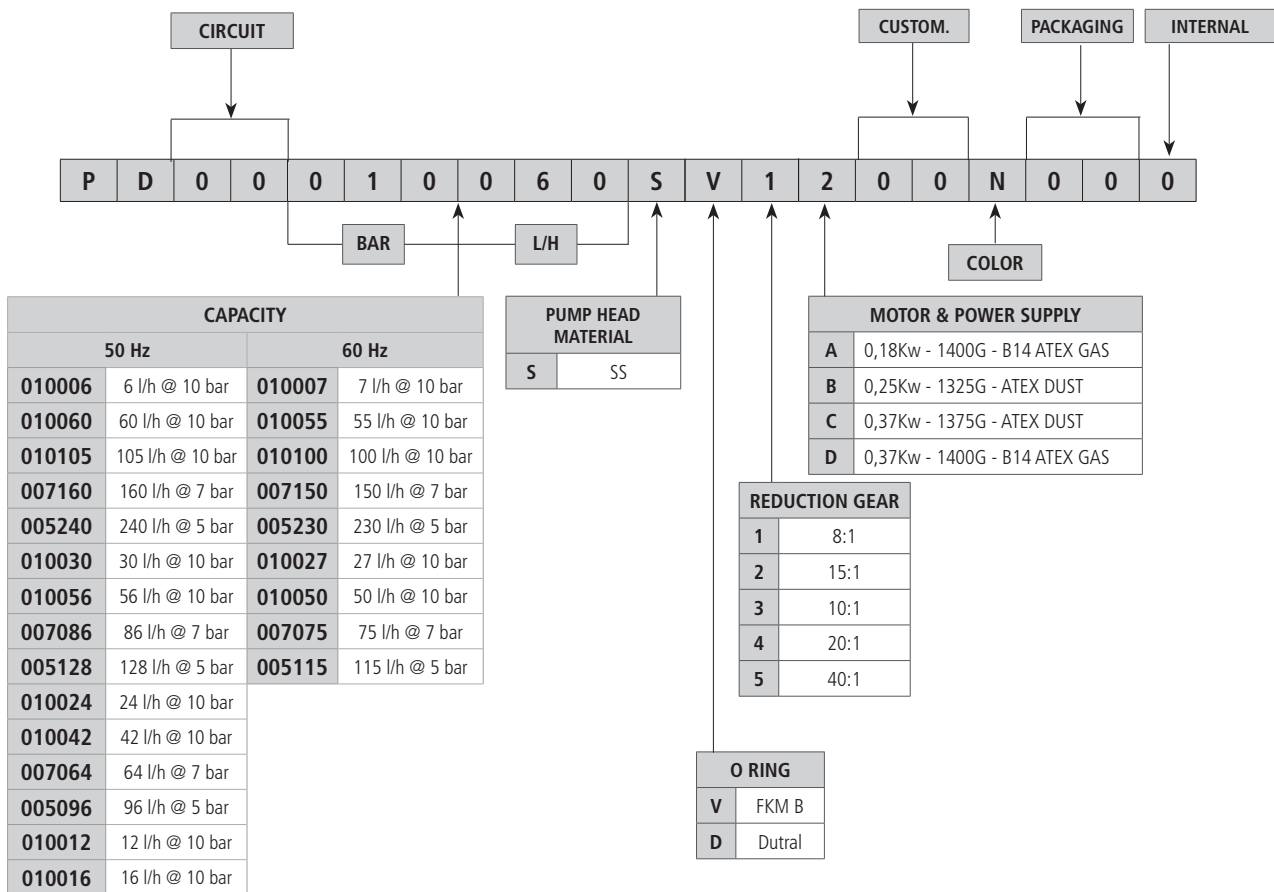

LUBRICANT TYPE	
BRAND	MODEL
MOBIL	MOBILGEAR 632
SHELL	OMALA OIL 320
BP	ENERGOL GR-XP 320
IP	MELLANA OIL 320
ESSO	SPARTAN EP 320
AGIP	BLASIA 320

# PRIUS

## Motor driven diaphragm metering pump

### “PRIUS” SERIES - 50 Hz / 3-PHASE MOTOR

#### Features

- Aluminium enclosure (epoxy coating)
- Spring return mechanism
- Power supply 220-240/380-420 V - Δ/Y
- Environment temperature: -10 ÷ 40°C (14 ÷ 104°F)
- Chemical temperature with SS pump head: -10 ÷ 90°C (14 ÷ 194°F)\*
- Installation class ..... II
- Pollution level ..... 2
- Audible noise..... 78 dbA (± 5 dB)
- Protection degree ..... IP 55
- Max suction height ..... 3 m
- Oil capacity..... 0,3 lt (Refer to “Lubricant type” table)

\* The specified temperature can be exceeded temporarily (max 15') for sterilization or flushing with hot water.

## PRIUS

### Motor driven diaphragm metering pump

PRIUS - 50 Hz

Power supply..... 220-240/380-420 V - Δ/Y

PRIUS 50 Hz - ATEX GAS									
MODELS	PRESSURE		CAPACITY		STROKE / 1'	MOTOR	REDUCTION GEAR	PUMP HEAD MODEL	HOSE CONNECTION
	bar	PSI	l/h	GPH				SS	SS PUMP HEAD
010006	10	145	6	1,58	35	0,18 kW	40 : 1	NM	R1/2" G1/2"
010060	10	145	60	15,8	175	0,18 kW	8 : 1	NM	R1/2" G1/2"
010105	10	145	105	27,7	175	0,37 kW	8 : 1	TM	R3/4" G3/4"
007160	7	101,5	160	42,3	175	0,37 kW	8 : 1	TM	R3/4" G3/4"
005240	5	72,5	240	63,4	175	0,37 kW	8 : 1	TM	R3/4" G3/4"
010030	10	145	30	7,9	94	0,18 kW	15 : 1	NM	R1/2" G1/2"
010056	10	145	56	14,8	94	0,37 kW	15 : 1	TM	R3/4" G3/4"
007086	7	101,5	86	22,7	94	0,37 kW	15 : 1	TM	R3/4" G3/4"
005128	5	72,5	128	33,8	94	0,37 kW	15 : 1	TM	R3/4" G3/4"
010024	10	145	24	6,3	70	0,18 kW	20 : 1	NM	R1/2" G1/2"
010042	10	145	42	11,1	70	0,37 kW	20 : 1	TM	R3/4" G3/4"
007064	7	101,5	64	16,9	70	0,37 kW	20 : 1	TM	R3/4" G3/4"
005096	5	72,5	96	25,4	70	0,37 kW	20 : 1	TM	R3/4" G3/4"
010012	10	145	12	3,17	35	0,18 kW	40 : 1	NM	R1/2" G1/2"
010016	10	145	16	4,22	35	0,18 kW	40 : 1	NM	R1/2" G1/2"

PRIUS 50 Hz - ATEX DUST									
MODELS	PRESSURE		CAPACITY		STROKE / 1'	MOTOR	REDUCTION GEAR	PUMP HEAD MODEL	HOSE CONNECTION
	bar	PSI	l/h	GPH				SS	SS PUMP HEAD
010006	10	145	6	1,58	35	0,18 kW	40 : 1	NM	R1/2" G1/2"
010060	10	145	60	15,8	175	0,25 kW	8 : 1	NM	R1/2" G1/2"
010105	10	145	105	27,7	175	0,37 kW	8 : 1	TM	R3/4" G3/4"
007160	7	101,5	160	42,3	175	0,37 kW	8 : 1	TM	R3/4" G3/4"
005240	5	72,5	240	63,4	175	0,37 kW	8 : 1	TM	R3/4" G3/4"
010030	10	145	30	7,9	94	0,25 kW	15 : 1	NM	R1/2" G1/2"
010056	10	145	56	14,8	94	0,37 kW	15 : 1	TM	R3/4" G3/4"
007086	7	101,5	86	22,7	94	0,37 kW	15 : 1	TM	R3/4" G3/4"
005128	5	72,5	128	33,8	94	0,37 kW	15 : 1	TM	R3/4" G3/4"
010024	10	145	24	6,3	70	0,25 kW	20 : 1	NM	R1/2" G1/2"
010042	10	145	42	11,1	70	0,37 kW	20 : 1	TM	R3/4" G3/4"
007064	7	101,5	64	16,9	70	0,37 kW	20 : 1	TM	R3/4" G3/4"
005096	5	72,5	96	25,4	70	0,37 kW	20 : 1	TM	R3/4" G3/4"
010012	10	145	12	3,17	35	0,25 kW	40 : 1	NM	R1/2" G1/2"
010016	10	145	16	4,22	35	0,25 kW	40 : 1	NM	R1/2" G1/2"

# PRIUS

## Motor driven diaphragm metering pump

### "PRIUS" SERIES - 60 Hz / 3-PHASE MOTOR

#### Features

- Aluminium enclosure (epoxy coating)
- Spring return mechanism
- Power supply: 40-480 V - Y connection
- Environment temperature:  $-10 \div 40^{\circ}\text{C}$  ( $14 \div 104^{\circ}\text{F}$ )
- Chemical temperature with SS pump head:  $-10 \div 90^{\circ}\text{C}$  ( $14 \div 194^{\circ}\text{F}$ )\*
- Installation class .....II
- Pollution level .....2
- Audible noise.....78 dbA ( $\pm 5$  dB)
- Protection degree .....IP 55
- Max suction height .....3 m
- Oil capacity.....0,3 lt (Refer to "Lubricant type" table)

\* The specified temperature can be exceeded temporarily (max 15') for sterilization or flushing with hot water.

## PRIUS

### Motor driven diaphragm metering pump

PRIUS - 60 Hz

Power supply..... 440-480 V - Y

PRIUS 60 Hz - ATEX GAS									
MODELS	PRESSURE		CAPACITY		STROKE / 1'	MOTOR	REDUC-TION GEAR	PUMP HEAD MODEL	HOSE CONNECTION
	bar	PSI	l/h	GPH				SS	SS PUMP HEAD
010007	10	145	7	1,85	35	0,18 kW	40 : 1	NM	R1/2" G1/2"
010055	10	145	55	15,4	175	0,18 kW	10 : 1	NM	R1/2" G1/2"
010100	10	145	100	26,4	175	0,37 kW	10 : 1	TM	R3/4" G3/4"
007150	7	101,5	150	39,6	175	0,37 kW	10 : 1	TM	R3/4" G3/4"
005230	5	72,5	230	60,8	175	0,37 kW	10 : 1	TM	R3/4" G3/4"
010027	10	145	27	7,1	87	0,18 kW	20 : 1	NM	R1/2" G1/2"
010050	10	145	50	13,2	87	0,37 kW	20 : 1	TM	R3/4" G3/4"
007075	7	101,5	75	19,8	87	0,37 kW	20 : 1	TM	R3/4" G3/4"
005115	5	72,5	115	30,4	87	0,37 kW	20 : 1	TM	R3/4" G3/4"

PRIUS 60 Hz - ATEX DUST									
MODELS	PRESSURE		CAPACITY		STROKE / 1'	MOTOR	REDUC-TION GEAR	PUMP HEAD MODEL	HOSE CONNECTION
	bar	PSI	l/h	GPH				SS	SS PUMP HEAD
010007	10	145	7	1,85	35	0,25 kW	40 : 1	NM	R1/2" G1/2"
010055	10	145	55	15,4	175	0,25 kW	10 : 1	NM	R1/2" G1/2"
010100	10	145	100	26,4	175	0,37 kW	10 : 1	TM	R3/4" G3/4"
007150	7	101,5	150	39,6	175	0,37 kW	10 : 1	TM	R3/4" G3/4"
005230	5	72,5	230	60,8	175	0,37 kW	10 : 1	TM	R3/4" G3/4"
010027	10	145	27	7,1	87	0,25 kW	20 : 1	NM	R1/2" G1/2"
010050	10	145	50	13,2	87	0,37 kW	20 : 1	TM	R3/4" G3/4"
007075	7	101,5	75	19,8	87	0,37 kW	20 : 1	TM	R3/4" G3/4"
005115	5	72,5	115	30,4	87	0,37 kW	20 : 1	TM	R3/4" G3/4"

# PRIUS

## Motor driven diaphragm metering pump

### Dimensions

DIMENSIONS (mm)		
	NM pump head (SS)	TM pump head (SS)
<b>A</b>	~ 320	~ 310
<b>B</b>	~ 280	~ 278
<b>C</b>	157	157
<b>L</b>	177	220
<b>G</b>	163	163
<b>H</b>	~ 190	~ 190
<b>I</b>	97,5	110
<b>F</b>	~ 400	~ 460
<b>E</b>	125,2	125,2
<b>D</b>	108,6	108,6
∅ fixing holes	8	8

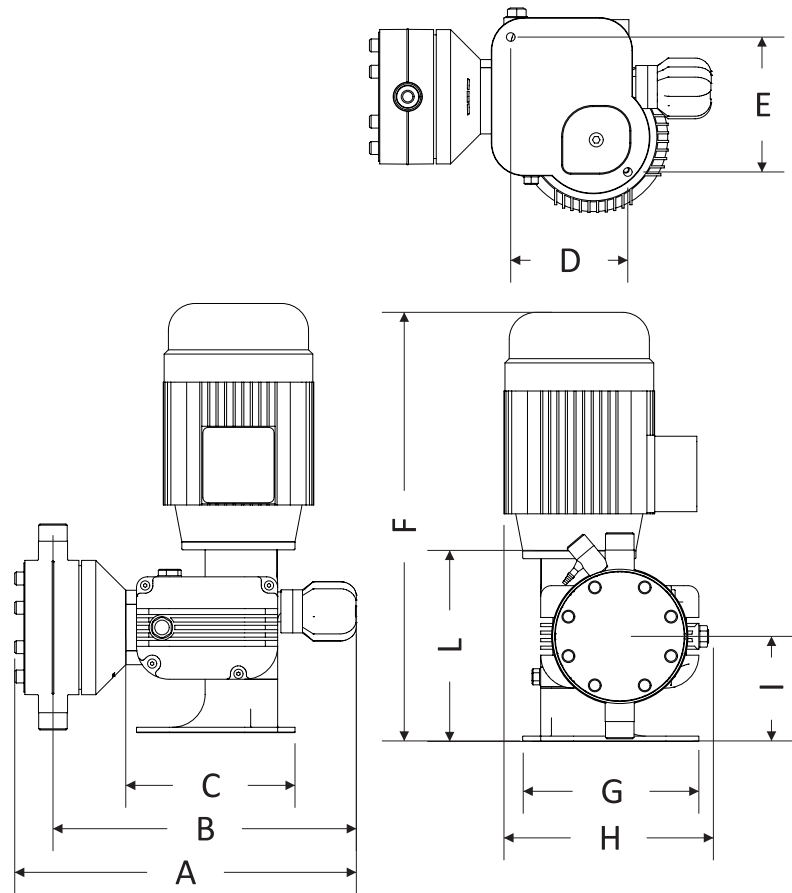

### Exploded view

