

EE776

Insertion Flowmeter for compressed air and gases DN50 - DN700 (2" - 28")

The EE776 flow meter is based on the thermal mass flow measurement and is ideal for measuring the flow of compressed air and gases in pipes from DN50 (2") to DN700 (28"). With the EE776, the consumption of compressed air, nitrogen, CO2 or other non-corrosive and non-flammable gases can be measured up to a pressure of 16 bar (232 PSI), for example.

Patented non-return protection for secure mounting

The EE776 flow meter set new standards in terms of safety and easy assembly. The patented non-return protection combines three functions in one device:

- **Non-return protection**
The sensor can only be pushed in one direction during installation. The sensor cannot return at all, even if it is released.
- **Seal**
By means of an encapsulated O-ring, no compressed air can escape under pressure during assembly.
- **Precise positioning**
The precise positioning with respect to immersion depth and orientation is easy to perform, guaranteeing accurate measurement results.

The high measurement accuracy of 1.5% from reading results from the application-oriented factory adjustments, which are undertaken at 9 bar (130 PSI) pressure. For optimum adaptation to different measurement tasks, you can choose between two measuring ranges 0.2...100 Nm/s (40...19685 SFPM) or 0.2...200 Nm/s (40...39370 SFPM) and three different probe lengths with a maximum immersion depth of 165 mm (6.5") / 315 mm (12.4") / 465 mm (18.3"). The inner diameter of the distribution pipe which is measured can be entered via the USB port and the included configuration software.

Two signal outputs are available to output the measured values. Depending on the application, these can be configured as an analogue output (current or voltage), switching output or pulse output for consumption measuring.

Bus interface for Modbus RTU or M-Bus

Optionally, the flow meter is available with an additional bus interface for MODBUS RTU or M-BUS (Meter-Bus).

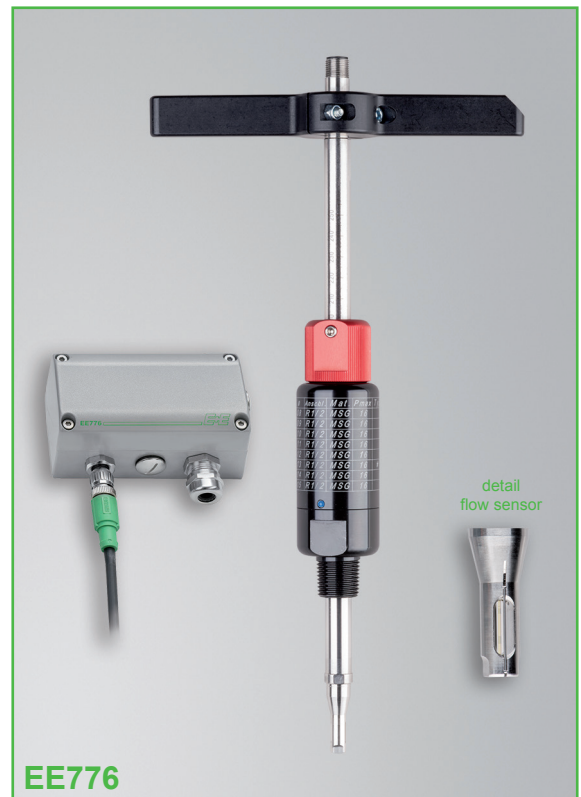

EE776

Typical Applications

Measurement of consumption of compressed air
Compressed air counter
Mass flow measurement of industrial gases

Features

Non-return protection for secure mounting
Assembly/disassembly under pressure without flow interruption
easy and accurate positioning
high accuracy $\pm 1.5\%$ of reading
factory adjustment under pressure
Pipe diameters DN50 (2") to DN700 (28")
Pressure range up to 16 bar (232 PSI)
Wide measuring range up to 200 Nm/s (39370 SFPM)
Bus interface for Modbus RTU or M-Bus

Design

The EE776 flow meter has a modular design and consists of probes (1) and evaluation electronics (2). The probe includes sensor and measuring electronics, in which the factory adjustment data is stored. The evaluation electronics communicates digitally with the probe and can be located up to 10 m (32.8 ft) from the probe.

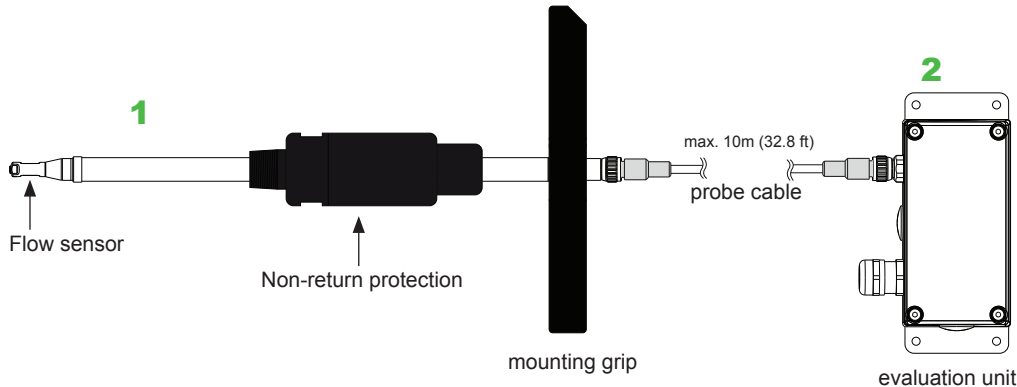

Assembly

With the right accessories, the EE776 flow meter can be easily integrated into any measurement task.

An assembly without welding and drilling into the pressurised supply line without flow interruption, can be implemented very easily with the tapping sleeve. An optional 1/2" ball valve on the tapping sleeve enables the installation and removal of the sensor without interrupting the flow in the compressed air line. The ball valve on the tapping sleeve closes the measuring point pressure-tight after removing the flow meter. Regular calibration, without taking into account the device downtime, is therefore always an option.



Measurement of consumption (totalizer)

The EE776 holds an integrated counter for the usage. The amount is stored and the data will not be lost due to a power outage. The availability of the consumption amount as a free configurable pulse output is another helpful feature.

Configuration software

The EE776 flowmeter can be configured conveniently, to meet the requirements of the application with the standard configuration software and the integrated USB interface.

Functionality:

- Configuration of the output (scale / set point)
- Setting the pipe diameter
- 2-point user calibration for flow and temperature
- Readout of the counter values
- Reset of min / max values and counter
- Indication of the measurement value
- Configuration of the bus interface

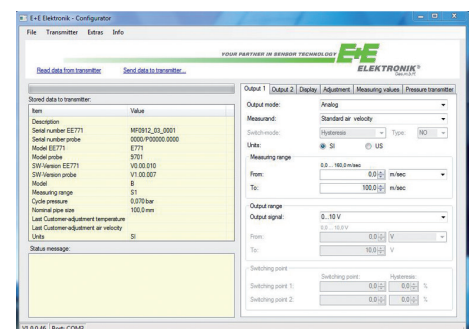

Dimensions in mm (inch)

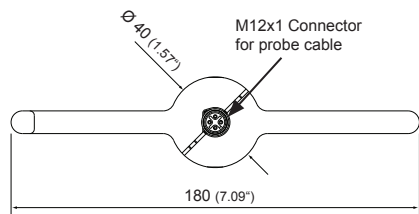
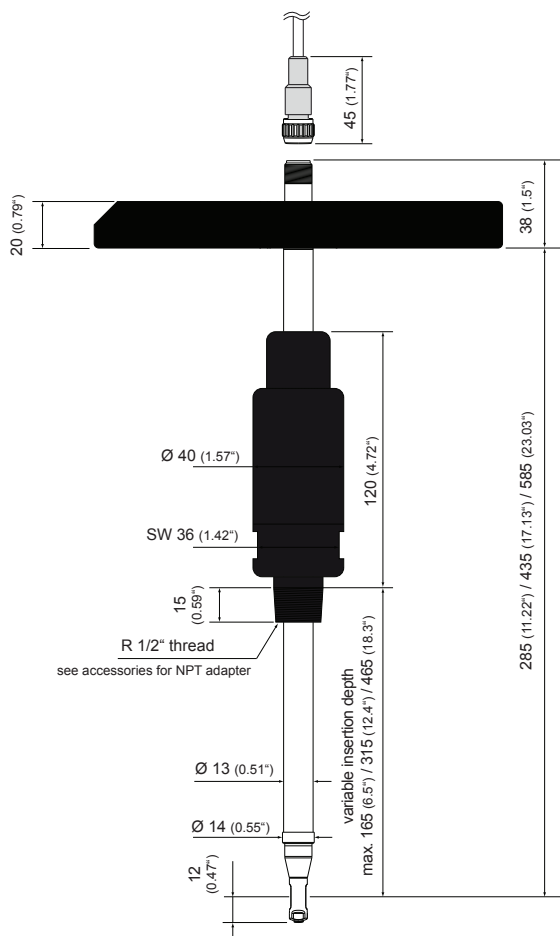

EE776
Sensor probe

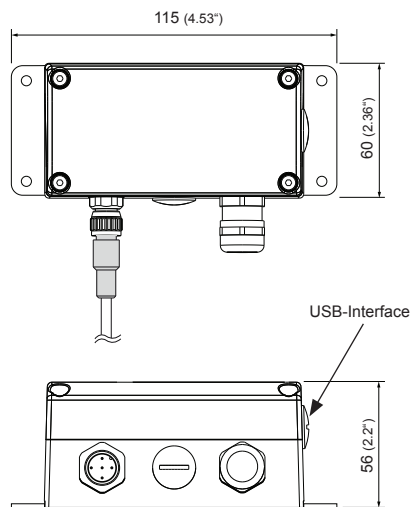

EE776
Enclosure - signal conditioning unit

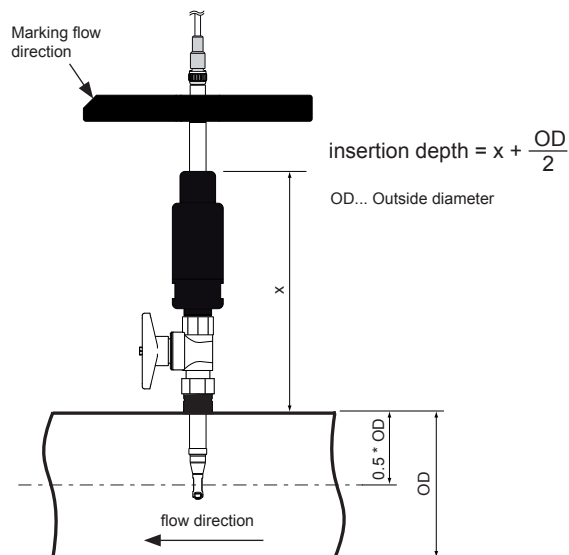

EE776
Assembly - insertion depth

Dimensions accessories in mm (inch)

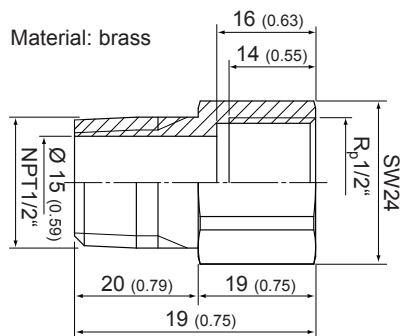

HA074004
Adapter BSP - NPT

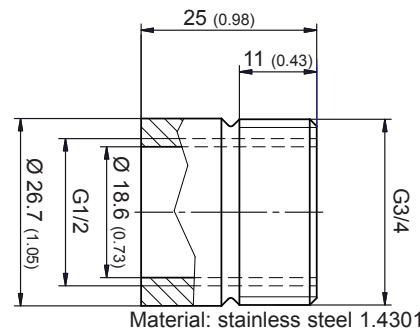

HA074001
Welding nipple

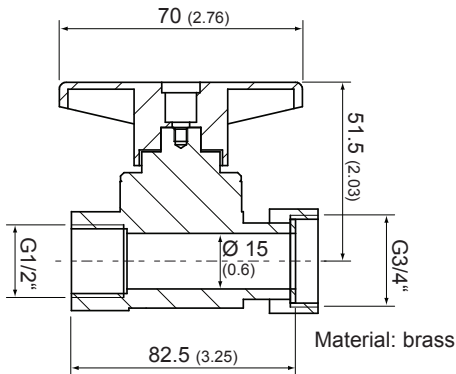

HA074002
Ball valve 1/2"

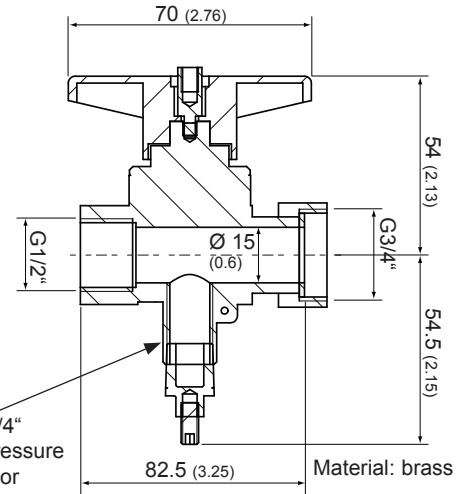

HA074003
Ball valve 1/2" for parallel measurement

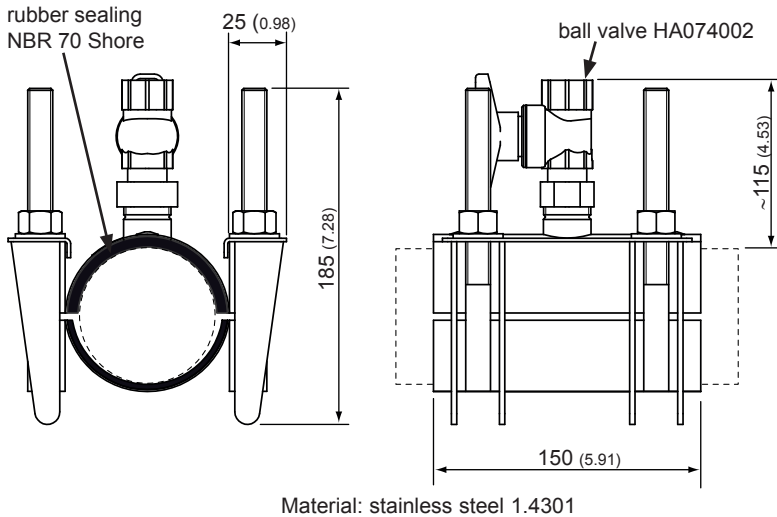

HA074xxx
Tapping sleeve (delivery without ball valve)

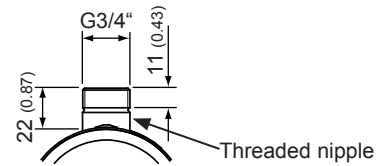

pipe	clamping range [mm (inch)]	max. working pressure
DN50 (2")	47 - 67 (1.85 - 2.64)	16bar (232psi)
DN65 (2 1/2")	73 - 93 (2.87 - 3.66)	16bar (232psi)
DN80 (3")	86 - 106 (3.39 - 4.17)	16bar (232psi)
DN100 (4")	107 - 127 (4.21 - 5.00)	16bar (232psi)
DN125 (5")	128 - 148 (5.04 - 5.83)	16bar (232psi)
DN150 (6")	149 - 171 (5.87 - 6.73)	16bar (232psi)
DN200 (8")	216 - 236 (8.50 - 9.29)	16bar (232psi)
DN250 (10")	260 - 280 (10.24 - 11.02)	10bar (145psi)
DN300 (12")	315 - 335 (12.40 - 13.19)	10bar (145psi)

Connection Diagram

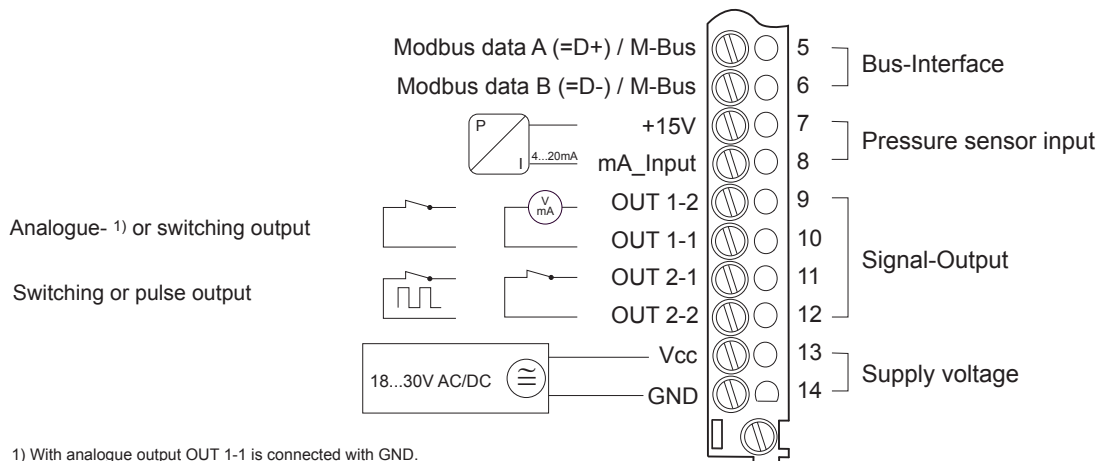

1) With analogue output OUT 1-1 is connected with GND. Switching and pulse output are potential-free.

Technical Data

Measuring value

Flow	
Measurand	Volumetric flow at standard conditions acc. DIN 1343 $P_0 = 1013.25 \text{ mbar (14.7 PSI)}$; $t_0 = 0 \text{ }^\circ\text{C (32 }^\circ\text{F)}$
Measuring range	0.2...100 Nm/s (40...19685 SFPM) or 0.2...200 Nm/s (40...39370 SFPM)
Accuracy in air at 9bar (130.5psi) (abs) and 23°C (73°F) ¹⁾	± (1.5% of measuring value + 0.8% of full scale)
Temperature coefficient	± (0.1% of measuring value / °C)
Pressure coefficient ²⁾	+ 0.5% of measuring value / bar
Response time t_{90}	< 1 sec.
Sample rate	0.5 sec.
Temperature	
Measuring range	-20...80 °C (-4...176 °F)
Accuracy at 20°C (68°F)	± 0.7 °C (1.26 °F)

Outputs

Output signal and display ranges are freely scalable	
Analogue output	voltage 0 - 10 V max. 1 mA current (3-wire) 0 - 20 mA and 4 - 20 mA $R_L < 500 \text{ Ohm}$
Switching output	potential-free max. 44 VDC, 500 mA switching capacity
Pulse output	Totalizer, pulse length: 0.02...2 sec.
Bus interface	MODBUS RTU or M-BUS (Meter-Bus)
Digital interface	USB (for configuration)

Input

Optional pressure compensation	4 - 20 mA (2-wire; 15 V) for pressure sensor
--------------------------------	--

General

Supply voltage	18 - 30 V AC/DC
Current consumption	max. 200 mA
Temperature range	ambient temperature: -20...60 °C (-4...140 °F) medium temperature: -20...80 °C (-4...176 °F) storage temperature: -20...60 °C (-4...140 °F)
Humidity working range	0...99 %RH no condensation
max. working pressure	16 bar (232 Psi)
Medium	compressed air or Non-Corrosive gases
Electrical connection	cable gland M16x1.5 (optional connector M12x1 8pol.)
Electromagnetic compatibility	EN61326-1 EN61326-2-3 Industrial Environment
Material	housing: metal (AlSi3Cu) probe: stainless steel sensor head: stainless steel / glass non-return protection: brass
Housing protection class	IP65 / Nema 4



1) The accuracy statement includes the uncertainty of the factory calibration with an enhancement factor $k=2$ (2-times standard deviation). The accuracy was calculated in accordance with EA-4/02 and with regard to GUM (Guide to the Expression of Uncertainty in Measurement).

2) The flow meter is calibrated at 9 bar (abs) 130.5 psi. If the working pressure is different from 9 bar (130.5 psi) you can compensate the error by setting the actual pressure with the configuration software.

Flow measuring range in dependence on pipe diameter

pipe	inner Ø	measuring range	
		0.2...100 Nm/s (40...19685 SFPM)	0.2...200 Nm/s (40...39370 SFPM)
DN50 / 2"	54.5 (2.15")	1.7...839 Nm ³ /h 1.0...493.8 SCFM	1.7...1679 Nm ³ /h 1.0...987.6 SCFM
DN65 / 2 1/2"	70.3 (2.77")	2.8...1397 Nm ³ /h 1.6...821.6 SCFM	2.8...2793 Nm ³ /h 1.6...1643.2 SCFM
DN80 / 3"	82.5 (3.25")	3.8...1923 Nm ³ /h 2.3...1131.5 SCFM	3.8...3847 Nm ³ /h 2.3...2263.0 SCFM
DN100 / 4"	107.1 (4.22")	6.5...3242 Nm ³ /h 3.8...1906.9 SCFM	6.5...6483 Nm ³ /h 3.8...3813.8 SCFM
DN125 / 5"	131.7 (5.19")	9.8...4902 Nm ³ /h 5.8...2883.5 SCFM	9.8...9803 Nm ³ /h 5.8...5766.9 SCFM
DN150 / 6"	159.3 (6.27")	14.3...7171 Nm ³ /h 8.4...4218.7 SCFM	14.3...14343 Nm ³ /h 8.4...8437.3 SCFM
DN200 / 8"	206.5 (8.13")	24.1...12051 Nm ³ /h 14.2...7089.0 SCFM	24.1...24101 Nm ³ /h 14.2...14178.0 SCFM
DN250 / 10"	260.4 (10.25")	38.3...19163 Nm ³ /h 22.5...11272.6 SCFM	38.3...38325 Nm ³ /h 22.5...22545.3 SCFM
DN300 / 12"	309.7 (12.19")	54.2...27105 Nm ³ /h 31.9...15945.1 SCFM	54.2...54211 Nm ³ /h 31.9...31890.1 SCFM
DN350 / 14"	339.6 (13.37")	65.2...32591 Nm ³ /h 38.3...19172.5 SCFM	65.2...65183 Nm ³ /h 38.3...38345.0 SCFM
DN400 / 16"	388.8 (15.31")	85.4...42719 Nm ³ /h 50.3...25130.2 SCFM	85.4...85438 Nm ³ /h 50.3...50260.0 SCFM
DN500 / 20"	486 (19.13")	133.5...66749 Nm ³ /h 78.5...39266.0 SCFM	133.5...133498 Nm ³ /h 78.5...78531.9 SCFM
DN600 / 24"	585 (23.03")	193.4...96712 Nm ³ /h 113.8...56892.6 SCFM	193.4...193425 Nm ³ /h 113.8...113785.1 SCFM
DN700 / 28"	682.6 (26.87")	263.4...131675 Nm ³ /h 154.9...77459.8 SCFM	263.4...263350 Nm ³ /h 154.9...154919.6 SCFM

Formula for calculating the standardized volumetric flow:

$$V'_n = v_n \cdot id^2 \cdot \pi/4 \cdot 3600$$

V'_n ... standardized volumetric flow [m³/h]

v_n ... standardized flow [m/s]

id ... inner pipe diameter [m]

π ... 3.1415

Ordering Guide

Position 1 - Flow meter

EE776-

Hardware Configuration	Model	remote probe	C	
	Working range	low 0.2...100 Nm/s (40...19685 SFPM)	L1	
		high 0.2...200 Nm/s (40...39370 SFPM)	H2	
	pipe diameter / probe length	DN50 (2") / 165 mm (6.5")	N050	
		DN65 (2 1/2") / 165 mm (6.5")	N065	
		DN80 (3") / 165 mm (6.5")	N080	
		DN100 (4") / 165 mm (6.5")	N100	
		DN125 (5") / 315 mm (12.4")	N125	
		DN150 (6") / 315 mm (12.4")	N150	
		DN200 (8") / 315 mm (12.4")	N200	
DN250 (10") / 315 mm (12.4")		N250		
DN300 (12") / 315 mm (12.4")		N300		
DN350 (14") / 465 mm (18.3")		N350		
DN400 (16") / 465 mm (18.3")		N400		
DN500 (20") / 465 mm (18.3")		N500		
DN600 (24") / 465 mm (18.3")	N600			
DN700 (28") / 465 mm (18.3")	N700			
Display	without Display	x		
	with Display	D		
Electrical connection	cable gland M16x1.5	A		
	1 plug M12x1 for power supply and outputs	Q		
Bus-Interface	without bus-interface	x		
	Modbus RTU	1		
	M-Bus (Meter-Bus)	5		
Software Configuration	Physical parameters of output 1	Temperature	T [°C] [°F]	B
		standardized volumetric flow	V _n [Nm ³ /h] [SCFM]	R
		mass flow	m ^l [kg/h]	S
		standardized flow	v _n [Nm/s] [ft ³ /min]	T
	Physical parameters of output 2	Temperature	T [°C] [°F]	B
		standardized volumetric flow	V _n [Nm ³ /h] [SCFM]	R
		mass flow	m ^l [kg/h]	S
		standardized flow	v _n [Nm/s] [ft ³ /min]	T
	Output 1		0-5 V	2
			0-10 V	3
		analogue output	0-20 mA	5
			4-20 mA	6
Output 2	switching output		S	
		pulse output ¹⁾	I	
Measured value unit	metric / SI	M		
	non metric US / GB	N		
Medium	air	A		
	nitrogen	B		
	CO2	C		
	argon	G		

Position 2 - probe cable

cable length	2 m	HA010816
	5 m	HA010817
	10 m	HA010818

1) consumption measuring is possible only with pulse output (output 2 = I)

Accessories

tapping sleeve DN50 (2")	HA074050	welding nipple	HA074001
tapping sleeve DN65 (2 1/2")	HA074065	ball valve 1/2"	HA074002
tapping sleeve DN80 (3")	HA074080	ball valve 1/2" for parallel measurement	HA074003
tapping sleeve DN100 (4")	HA074100	adapter R _p 1/2" IT to NPT 1/2" ET	HA074004
tapping sleeve DN125 (5")	HA074125		
tapping sleeve DN150 (6")	HA074150		
tapping sleeve DN200 (8")	HA074200	Dew point sensor	see data sheet EE371
tapping sleeve DN250 (10")	HA074250	Sampling cell for dew point sensor	HA050102
tapping sleeve DN300 (12")	HA074300	Quick coupling G1/4" ET	HA070203

Order Example

Position 1 - Flow meter

EE776-CL1N100xAx/RI6IMA

Model:	remote probe
Working range:	0.2...100 Nm/s
pipe diameter - probe length:	DN100 / 165 mm
Display:	without Display
El. connection:	cable gland
Bus-Interface:	without bus-interface
Phys. parameter output 1:	standardized volumetric flow
Phys. parameter output 2:	consumption
Output 1:	4-20mA
Output 2:	pulse output
Measured value unit:	metric SI
Medium:	air

Position 2 - probe cable

HA010816
 probe cable 2m