

MINI TYPE WHEEL SIGHT FLOW METER Serie HF150

Technical Data

Connection Size: 1/4", 3/8", 1/2" and 3/4" NPT female standard;
PT, BSP(PF) thread available

Power Supply: 3.8V to 30VDC

Output: Sink (NPN)

Material: Body- CF8M; Window- PC; Cover- ABS;
Wheel- PVDF; Shaft- SS316; Bearings- PVDF+POM;
Cable- PVC; O-Ring- NBR

Housing Protection: IP65

Measuring Fluid: Cooling water and various liquids (Non-Corrosive Liquid)

Working Viscosity: Less than 2 cps

Working Temperature: Standard 0~50°C

Working Pressure: Maximum 1.0 MPa @25°C

Accuracy: Pulse output linearity: ±3%F.S

Installation: Horizontal or Vertical available

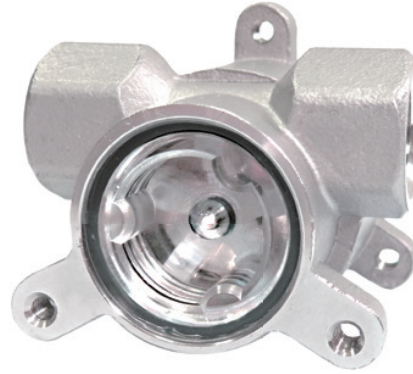

Approvals:



Mounting Position

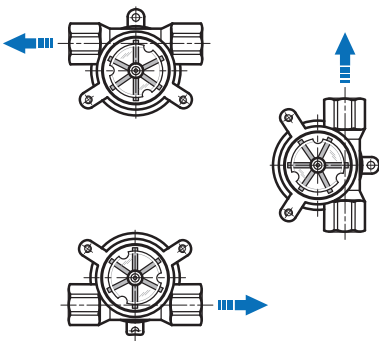

Range Table

SIZE	FLOW RATES (LPM)	NOMINAL FACTORS PER LITER	ΔP (mmH ₂ O)
1/4"	1.5~8	k=1420	2000
3/8"	2~20	k=930	2000
1/2"	7~70	k=195	1500
3/4"	10~100	k=142	1500

Dimensions-mm

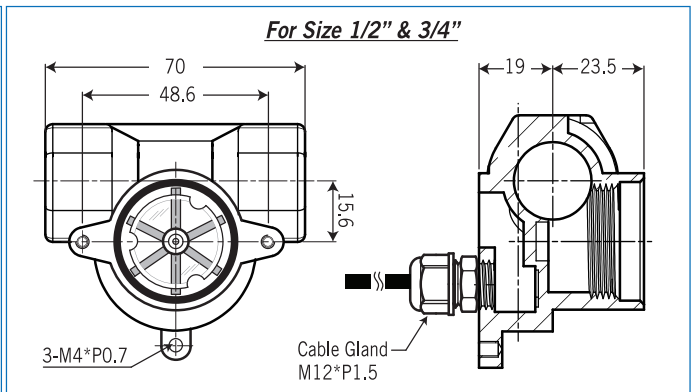
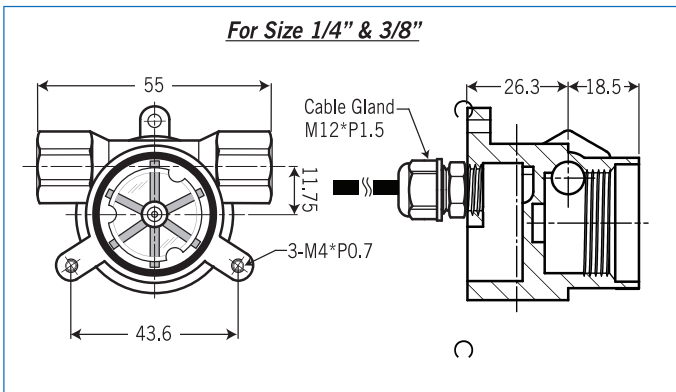

Wire Drawing

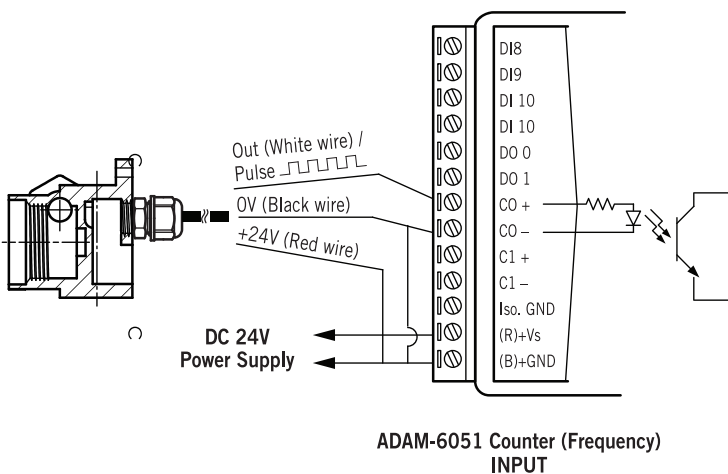

Ordering information

HF150	Code	Process Connection Size
		(1) 1/4" (2) 3/8" (3) 1/2" (4) 3/4"
	Code	Thread Type
	N	NPT female, standard
	P	PT female
	B	BSP(PF) female
	Code	Body Material
	A	CF8M
	Code	Cover Material
	1	ABS
	Code	Output
	1	Sink (NPN) output

Complete Ordering Code: HF150 [] [] [] [] []