

metraflow

non invasive PFA ultrasonic ow meter



General Information

Metraflow Non-invasive flow meter for challenging liquids.

- Straight through construction.
- Patented ultrasonic technology.
- No dead areas or obstructions.
- PFA flow tube
- High accuracy time of flight measurement system
- Linearity 0.5% FSD ($\pm 1\%$ reading isothermal)
- Repeatability $\pm 0.1\%$ plus $\pm 0.02\%$ FSD
- Wide flow range
- Compact body with built in display
- Free from ion contamination

Ideal for

- Semiconductor
- Pharmaceutical
- Medical
- Aggressive chemical metering
- Pilot plant

Description

The Metraflow through flow flowmeter uses Titan's patented transit time ultrasonic technology to accurately measure liquid travelling through a PFA flow tube. The compact integrated electronic, display and sensor package offers superior performance in a single assembly. Computer and operational connections are separate, permitting setting and interface monitoring during normal operation. The units, time base, set points and analogue and digital outputs can all be set through the USB connector and meter interface software. Other parameters such as minimum flow cut-off, computer based data logging, display/output filtration and a negative flow flag can also be configured through this port.

metraflow



Technical Specification

Flow range	1/8" tube	20 to 1000 ml/min
	1/4" tube	100 to 5000 ml/min
Linearity	± 0.5% FSD (* ±1% reading)	
Wetted components	PFA Tube; FDA Approved	
Repeatability	±0.1% plus ±0.02% FSD	
Max temp	60°C	
Working Pressure	1/8" tube	27.7bar(g)@25°C; 20.8bar(g)@60°C
	1/4" tube	16.7bar(g)@25°C; 12.6bar(g)@60°C
Display	6 digit LCD configurable with annunciators	
Outputs	Configurable 2 X "NPN" NFET input or output 1 X "PNP" PFET input or output 4 to 20mA 0 to 5/10V dc	
USB	Interface and programming connection (Mini B)	
Configurable	Rate and/or Total	
	Units	
	Time base	
	High/low flow alarms with hysteresis	
	Analogue outputs (4 - 20 mA, 0 - 5/10V)	
	Pulse output up to 10kHz	
Power Supply	12 to 24V dc	
	USB 5V with limited functionality	
Connections	Fluid	300mm tube tails
	Electrical	Via 8 way cable and/or USB
Order codes	1/8" tube	240-020
	1/4" tube	240-025

* ±1% Reading in isothermal conditions

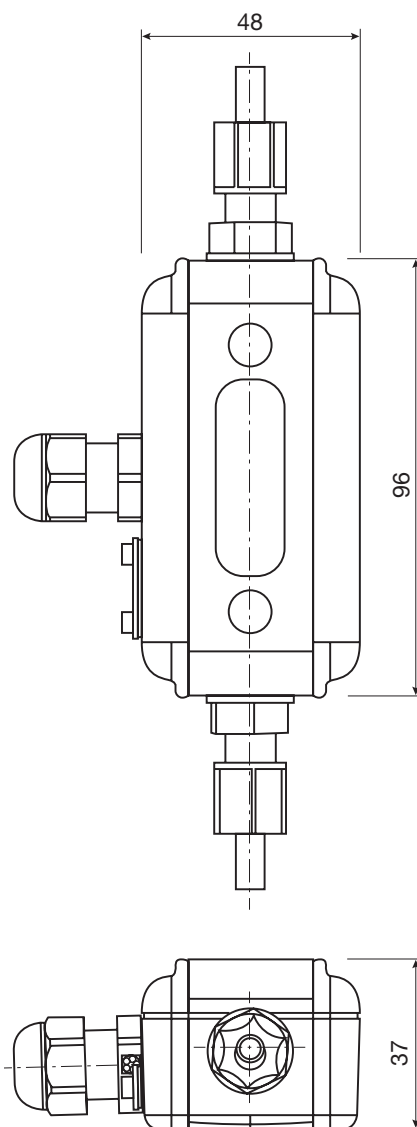

Metraflow Schematic showing Through Tube Assembly

