

MASS FLOWMETER WITH DISPLAY MAX 100 lmin Serie TLF

±1% Accuracy
Linear Output
Thermal Technology
For Using in Non Corrosive Gas
For Flow Rates up to 100 SLM
Power Supply Included

The NEW-FLOW Thermal Mass Flow Meters provide high performance. Thermal Technology offers advantages in accuracy, sensitivity and turn quality components and the latest technology are combined to provide reliable, compact meters and controllers. The TLF Series comes two type: With or Without an LCD Display; or Flow Rate with Totalizer LCD Display. All models come with linear 0-5VDC and 4-20mA output. The TLF Series measures the mass flow rate of gases in 23 ranges from 0-10 SCCM to 0-100 SLM as shown in the range table.

Technical Data

- Type:** Without LCD Display; Flow Rate with LCD Display; Flow Rate with LCD Display & Blue Back Lighted; Flow Rate with Totalizer LCD Display & Blue Back Lighted
- Wetted Parts Material:** Standard flowbody—SS316, Tapcon, option available. O-ring: Viton or FFKM available
- Output Signal:** 0-5 VDC Linear min. load 1000Ω or 4-20 mA Linear, loop resistance 500Ω
- Input Power:** 24VDC standard; optional power supply 15VDC 115VAC, 220VAC @500mA
- Accuracy:** ±1% F.S. (including linearity)
- Turn Down Ratio:** 100:1
- Repeatability:** ±0.15% F.S. or Better
- Electric Connection:** 9 Pin Sub "D"
- Process Connection:** 1/4" NPT female
- Range:** 0-10 SCCM to 0-100 SLM
- Minimum Pressure:** 40" H₂O
- Max. Pressure:** SS316— 500 psig; Tapcon— 250 psig
- Temperature Range:** 0~50°C
- Response Time:** 1 Second
- Temp. Coefficient:** 0.05% Full Scale per 1°C or Better
- Pressure Coefficient:** 0.01% Full Scale per PSIG or Better
- Flow Unit:** Kg, GAL, Nℓ, Nm³, cc, ℓ, M³
 (Flow rate with LCD display: Label by manufacturer;
 Flow rate with totalizer LCD display: Unit LCD display)
- Weight:** app. 1.08 kg with power supply
 app. 1.22 kg with power supply & totalizer

Dimensions

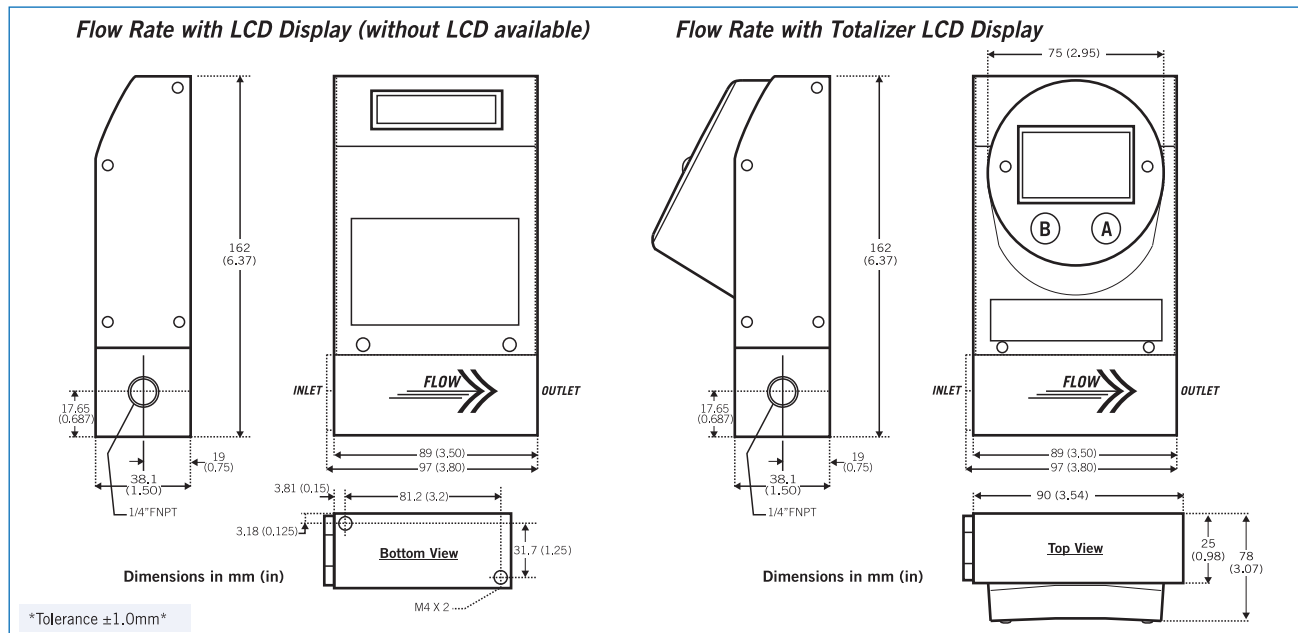

Approvals:



Display Digital Decimal Point Function

Flow Rate with LCD Display:

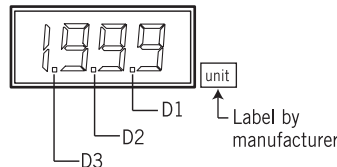

Range	Decimal Point
0 ~ 1,999	D3
2.0 ~ 19,99	D2
20.0 ~ 199,9	D1
200 ~ 1999	None

Flow Rate with Totalizer LCD Display :

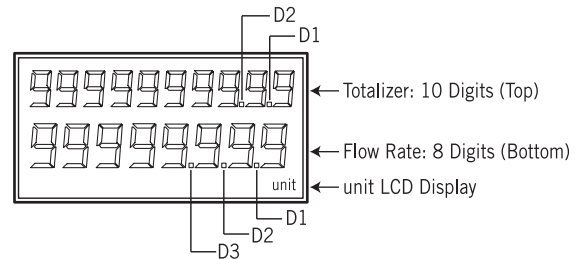

Range Table

Code	SCCM	Code	SLM	Code	SLM
00	0-10	06	0-1	14	0-35
01	0-20	07	0-2	15	0-40
02	0-50	08	0-5	16	0-45
03	0-100	09	0-10	17	0-50
04	0-200	10	0-15	18	0-55
05	0-500	11	0-20	19	0-60
		12	0-25	20	0-65
		13	0-30	21	0-70
				22	0-75
				23	0-100
				24	*Custom Flow Rate

NOTE.

*Please notice that the max. flow rate is 100 SLM.

Ordering Information

TLF	Code	Flow Range
↓	00~23	Please refer to the measure range table.
	24	*Custom range (please directly fill in the requested range)
		Code Wetted Parts Material
		A SS316 (Viton o-ring) B SS316 (FFKM o-ring) T Tapcon O option
		Code Process Connection
		1 ¼" NPT(F)
		Code Display
		W Flow Rate with LCD Display
		B Flow Rate with LCD Display & Blue Back Lighted
		T Flow Rate with Totalizer LCD Display & Blue Back Lighted
	O Without LCD Display	
	Code Output Signal	
	(1) 0~5 VDC (2) 4~20mA	
	Code Input Power	
	(1) 24 VDC (2) 15 VDC	
	Code Power Supply for 24 VDC	
	(1) With (2) Without	
↓	↓	↓
TLF		Complete Ordering Code

Flow Direction

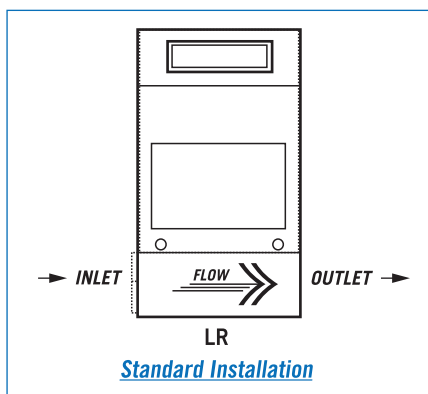

- Please follow the direction of arrow "→" on the label to install. (As shown on the left is the standard installation.)
- If customer requires "Vertical ↑ or ↓" installation, please contact with the manufacturer when place an order.