

MASS FLOW METERS

TMF SERIES – Flow Rate & Totalizer LCD Display

– Flow Rate With or Without LCD Display

- ±1% Accuracy
- Linear Output
- Thermal Technology
- For Using in Non Corrosive Gas
- For Flow Rates up to 200 SLM
- Power Supply Included

The NEW-FLOW Thermal Mass Flow Meters provide high performance. Thermal Technology offers advantages in accuracy, sensitivity and turn quality components and the latest technology are combined to provide reliable, compact meters and controllers. The TMF Series comes With or Without an LCD Display; or Flow Rate with Totalizer LCD Display. All models come with linear 0-5VDC and 4-20mA output. The TMF Series measures the mass flow rate of gases in 3 ranges from 0-100 SLM to 0-200 SLM as shown in the range table.



Technical Data

- Type:** Without LCD Display; Flow Rate with LCD Display; Flow Rate with LCD Display & Blue Back Lighted; Flow Rate with Totalizer LCD Display & Blue Back Lighted
- Wetted Parts Material:** Standard flowbody–SS316, option available. O-ring– Viton
- Output Signal:** 0-5 VDC Linear min. load 1000Ω or 4-20 mA Linear, loop resistance 500Ω
- Input Power:** 24VDC standard; optional power supply 15VDC 115VAC, 220VAC @500mA
- Accuracy:** ±1% F.S. (including linearity)
- Turn Down Ratio:** 100:1
- Repeatability:** ±0.15% F.S. or Better
- Electric Connection:** 9 Pin Sub "D"
- Process Connection:** 1/2"NPT female
- Range:** 0-100 SLM to 0-200 SLM
- Minimum Pressure:** 100" H₂O
- Max. Pressure:** 500 psig
- Temperature Range:** 0~50°C
- Response Time:** 1 Second
- Temp. Coefficient:** 0.05% Full Scale per 1°C or Better
- Pressure Coefficient:** 0.01% Full Scale per PSIG or Better
- Flow Unit:** Kg, GAL, Nℓ, Nm³, cc, ℓ, M³
(Flow rate with LCD display: Label by manufacturer; Flow rate with totalizer LCD display: Unit LCD display)
- Weight:** app. 1.64 kg with power supply
app. 1.78 kg with power supply & totalizer

Display Digital Decimal Point Function

Flow Rate with LCD Display:

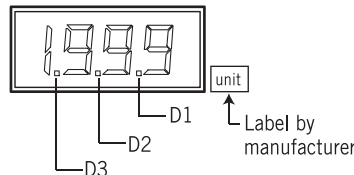

| Range | Decimal Point |
|--------------|---------------|
| 0 ~ 1.999 | D3 |
| 2.0 ~ 19.99 | D2 |
| 20.0 ~ 199.9 | D1 |
| 200 ~ 1999 | None |

Flow Rate with Totalizer LCD Display :

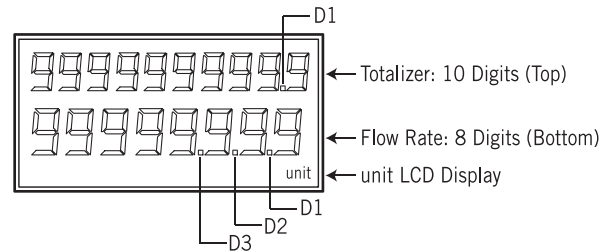

Dimensions

Flow Rate with LCD Display (without LCD available)

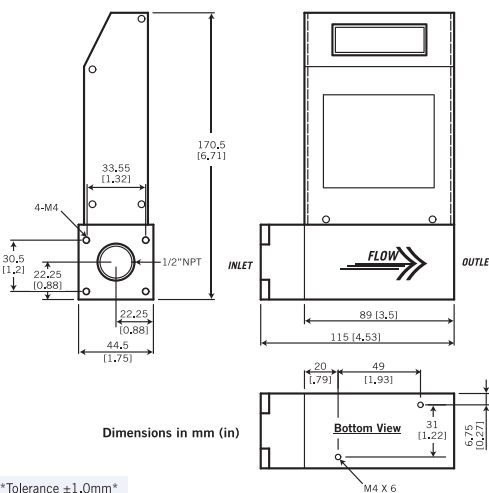

Flow Rate with Totalizer LCD Display

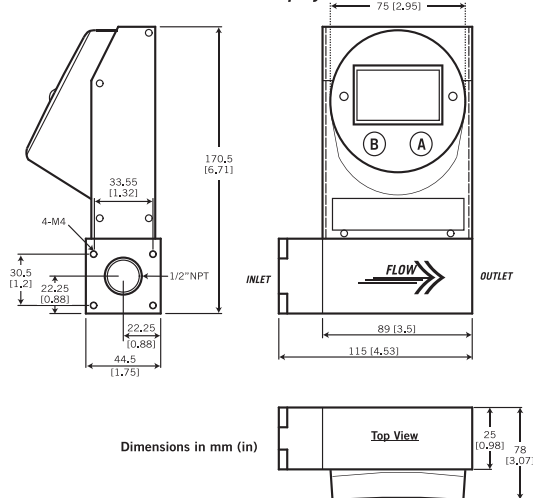

Tolerance ±1.0mm

