



The mixers are a perfect solution for mixing chemicals in small tanks (100 to 500 liters). The endless screw gear doesn't need lubrication.

Shaft made of stainless steel for maximum strength to mechanical stress

Comes with two standard speeds of 70 rpm in the configuration with gear / slow and fast 1400 rpm in the configuration. Other speeds can be defined on the basis of specific requests

Phase asynchronous motor 220-240V ± 5% 50 Hz, phase asynchronous motor supply voltage 380-420 V ± 5% 50 Hz. Both 4-pole.

### SPECIFICATIONS

|                    | Power |      | RPM  | Height (mm) | Paddle diameter (mm) | Shaft diameter (mm) | Execution |
|--------------------|-------|------|------|-------------|----------------------|---------------------|-----------|
|                    | Kw    | Hp   |      |             |                      |                     |           |
| Single-phase       | 0,09  | 0,12 | 1400 | 60-70-80-90 | 90                   | 21                  | PVC       |
| Single-phase       | 0,09  | 0,12 | 1400 | 60-70-80-90 | 90                   | 16                  | AISI      |
| <b>Three-phase</b> | 0,09  | 0,12 | 1400 | 60-70-80-90 | 90                   | 21                  | PVC       |
| <b>Three-phase</b> | 0,09  | 0,12 | 1400 | 60-70-80-90 | 90                   | 16                  | AISI      |
| Single-phase       | 0,09  | 0,12 | 70   | 60-70-80-90 | 210                  | 21                  | PVC       |
| Single-phase       | 0,09  | 0,12 | 70   | 60-70-80-90 | 210                  | 16                  | AISI      |
| <b>Three-phase</b> | 0,09  | 0,12 | 70   | 60-70-80-90 | 210                  | 21                  | PVC       |
| <b>Three-phase</b> | 0,09  | 0,12 | 70   | 60-70-80-90 | 210                  | 16                  | AISI      |

# MIXERS

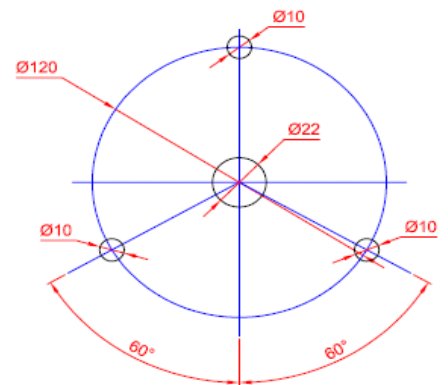
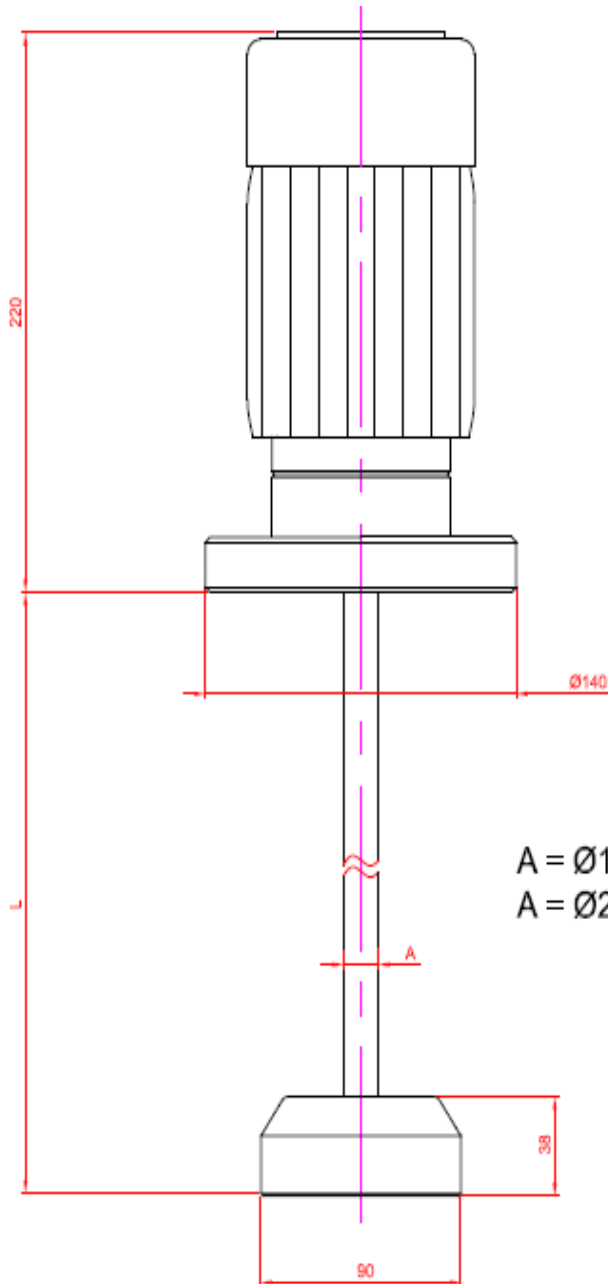

**DIMA DI FORATURA**

**DIMENSIONS ( mm )**  
**SLOW VERSION 70 RPM**

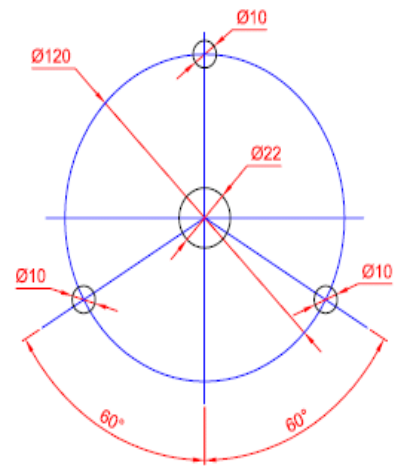
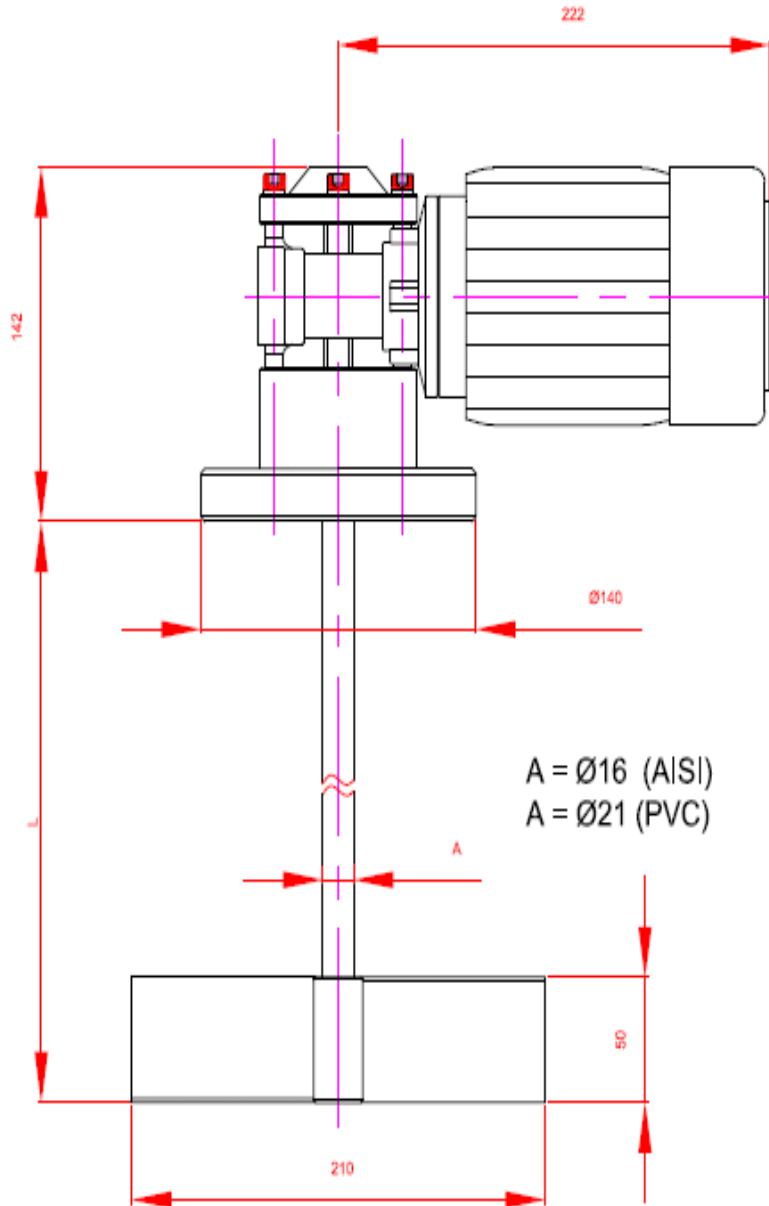

**DIMA DI FORATURA**

**DIMENSIONS ( mm )**  
**MANUAL MIXERS**

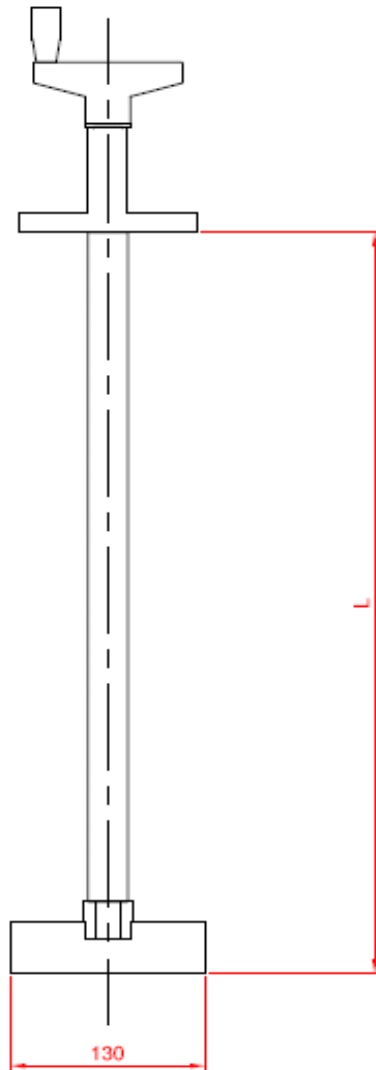

| CODICE     | DESCRIZIONE | "L" |
|------------|-------------|-----|
| 00.044.600 | MANUALE 60  | 60  |
| 00.044.601 | MANUALE 70  | 70  |
| 00.044.602 | MANUALE 80  | 80  |
| 00.044.603 | MANUALE 90  | 90  |
| 00.044.604 | MANUALE 100 | 100 |
| 00.044.605 | MANUALE 110 | 110 |
| 00.044.606 | MANUALE 45  | 45  |

**ADVICE**

**Main Features**

The mixer life span depends on the conditions of use. It is recommended to place the product in an environment not too humid to prevent the fumes from damaging the engine by causing it to malfunction. The use of the agitator must not be continuous but connected to a timer which enables the switching on and off.