



Vortex flow sensor

## Flow sensor for liquid media with display

### Type 212

The flow sensor type 212 is based on the Vortex trail principle. This flow sensor convinces due to the additional digital indicating device which shows the flow rate and the media temperature. The type 212 is available with and without temperature measurement.

With no moving parts the flow sensor is not sensitive to debris, has marginal pressure loss and high accuracy.



### Flow range

0.5 ... 150 l/min

### Nominal diameters

DN 6 / 8 / 10 / 15 / 20 / 25

### Temperature measurement

-20 ... +85 °C

- + Flow measuring with immediate display of flow measuring range and medium temperature
- + Temperature non-sensitive flow measuring principle
- + Excellent media resistance (measuring element not in contact with the media)
- + CE conformity
- + Wide application temperature range
- + Marginal loss of pressure
- + Measuring element not sensitive to debris
- + Direct temperature measurement in the medium
- + Drinking water approval

## Technical overview

### Flow measurement

Measuring principle	Vortex	Piezoelectric sensor element
Measuring range		0.5 ... 150 l/min
Nominal diameters		DN 6 / 8 / 10 / 15 / 20 / 25
Accuracy (via temperature) at < 50% fs (water)		< 1% fs
Accuracy (via temperature) at > 50% fs (water)		< 2% measuring value
Response time		Signal delay < 2 s
		Response time < 500 ms
		Display update rate < 500 ms

### Temperature measurement (≥ 8 DN)

4 ... 14.5 mA	Measuring range	-20 ... +85 °C
	Accuracy	± 1 K
	Calculation temperature	$T (^{\circ}\text{C}) = I [\text{mA}] - 6$ 0.1

### Operating conditions

Medium	Water	Other medium on request
Temperature	Media	< +85 °C
	Ambient	-20 ... +50 °C
	Storage	-30 ... +80 °C
Max. pressure and medium temperature	(for lifetime)	12 bar at +40 °C
	(for lifetime)	6 bar at +100 °C
Cavitation	(max. test pressure)	18 bar at +40 °C
	The following equation is valid to prevent cavitation:	$P_{\text{abs outlet}} / P_{\text{difference}} > 5.5$

### Materials in contact with medium

Sensor paddle	ETFE
Case with damming body	PA6T/6I (40% GF)
Sealing material	EPDM (perox.)
	FPM

### Electrical overview

Power supply	10 ... 30 VDC	
Output flow (Q)	4 ... 20 mA	
Output temperature (T)	4 ... 14.5 mA	
Electrical connection and IP protection	M12x1 (IP 65)	
Load	Flow	< $(U_N - 10 \text{ V}) / 20 \text{ mA}$
	Temperature	< $(U_N - 10 \text{ V}) / 14.5 \text{ mA}$
Current consumption max.	< 50 mA	
Electrical reliability	Short circuit, reverse voltage and external voltage protected within the admissible supply voltage.	

### Weight

DN 6 / 8	~ 90 g
DN 10	~ 105 g
DN 15	~ 115 g
DN 20	~ 135 g
DN 25	~ 150 g

### Test / Admissions

Electromagnetic compatibility	CE conformity acc. EN 61326-2-3
Shock acc. IEC 68-2-27	15 g, 6 ms, half sine wave, all 6 directions
Vibration acc. IEC 68-2-6	15 g, 61 ... 2000 Hz, 10 ... 61 Hz with amplitude ± 1 mm, 1 Octave/min. all 3 directions, 20 constant load
MTTF	577 years
Drinking water approval	WRAS
	Plastic parts with KTW and W270 approval

### Packaging

Single packaging	
Multiple packaging	

## Minimum life span on high flow rate and high temperature

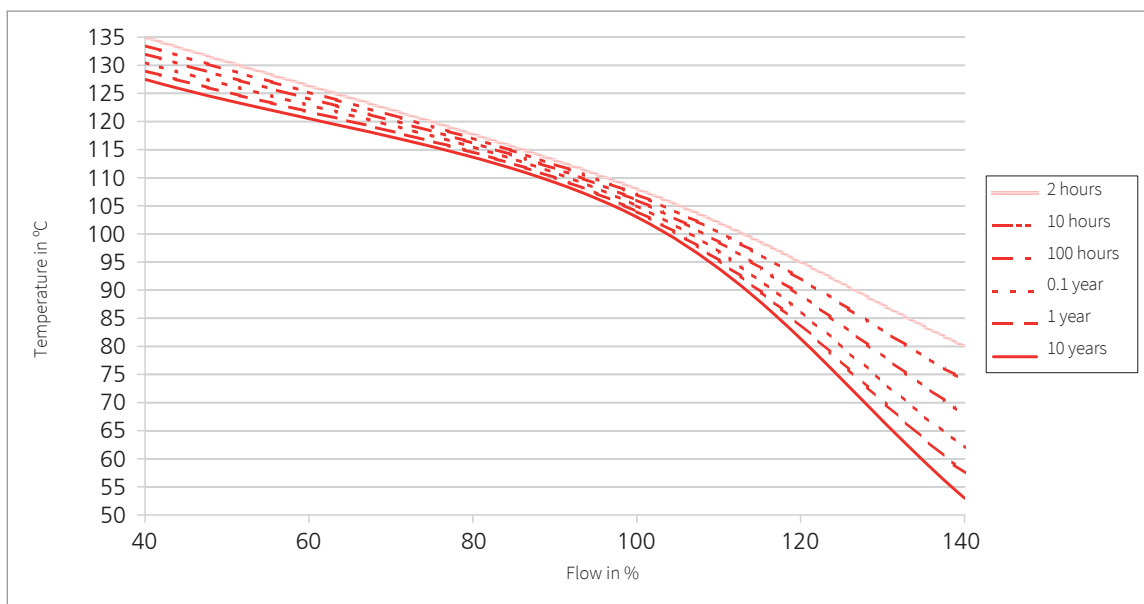

## Nominal diameters dependent variables

Nominal diameters	Tube connection	Measuring range	Flow range	K <sub>i</sub>	Pressure drop <sup>1),2)</sup>
DN 6	K	0.5 ... 10 l/min	0.074 ... 1.474 m/s	0.625	240 * Q <sup>2</sup>
	G				
DN 8	K	0.9 ... 15 l/min	0.133 ... 2.210 m/s	0.938	85.00 * Q <sup>2</sup>
	G				
	N				
DN 10	K	1.8 ... 32 l/min	0.265 ... 4.716 m/s	2.000	22.50 * Q <sup>2</sup>
	G				
	N				
DN 10	K	2.0 ... 40 l/min	0.295 ... 5.895 m/s	2.500	22.50 * Q <sup>2</sup>
	G				
	N				
DN 15	K	3.5 ... 50 l/min	0.290 ... 4.145 m/s	3.125	6.70 * Q <sup>2</sup>
	G				
	N				
DN 20	K	5.0 ... 85 l/min	0.265 ... 4.509 m/s	5.313	2.50 * Q <sup>2</sup>
	G				
	N				
DN 25	K	9.0 ... 150 l/min	0.283 ... 4.709 m/s	9.375	0.92 * Q <sup>2</sup>
	G				

### Characteristic line formula

#### current output

$$Q_V = K_i * (I_{OUT} - 4 \text{ mA})$$

### Legend

Q <sub>V</sub>	Volume flow rate	[l/min]
K <sub>i</sub>	Coefficient current output	[(l/min) / mA]
I <sub>OUT</sub>	Current	[mA]

## Order code selection table

		1	2	3	4	5	6	7	8	9
		<b>212. X X X X X X X X X X</b>								
Version	Flow	9			4					
	Flow and temperature	8			5					
Nominal diameters and flow rate	DN 6 0.5 ... 10 l/min. (with temperature on request)	9	0	6	4					K,G
	DN 8 0.9 ... 15 l/min.		0	8						
	DN 10 1.8 ... 32 l/min.		1	0						
	DN 10 2.0 ... 40 l/min.		1	1						
	DN 15 3.5 ... 50 l/min.		1	5						
	DN 20 5.0 ... 85 l/min.		2	0						
	DN 25 9.0 ... 150 l/min.		2	5						K,G
Output / power supply	Q: 4 ... 20 mA 10 ... 30 VDC (without temperature)	9			4					
	Q: 4 ... 20 mA T: 4 ... 14.5 mA 10 ... 30 VDC	8			5					
Display	2 lines static	8			5	0				
	1 line alternate (2s)	8			5	1				
	1 line static	9			4	2				
Unit temperature display	none (at Version „Flow“)	9			4		0			
	Degrees Celsius (°C)	8			5		C			
	Degrees Fahrenheit (°F)	8			5		F			
Unit flow display	Liter per minute (l/min)							M		
	Liter per second (l/s)							S		
Sealing material	EPDM									1
	FPM									2
Tube connection	Plastic PA6T / GI									
	connection copper tube (max. DN 20)									N
	outside thread K (see dimension diagram)									K
	outside thread G (see dimension diagram)									G

## Accessories (supplied loose)

## Order number

Connection kit <sup>3)</sup> DN 8, 10 with copper tube										113775
Connection kit <sup>3)</sup> DN 8, 10 with adapter Rp 3/8 (inside)	Stainless steel 1.4305/AISI 303									113776
Connection kit <sup>3)</sup> DN 15 with copper tube										113777
Connection kit <sup>3)</sup> DN 15 with adapter Rp 1/2 (inside)	Stainless steel 1.4305/AISI 303									113778
Connection kit <sup>3)</sup> DN 20 with copper tube										113779
Connection kit <sup>3)</sup> DN 20 with adapter Rp 3/4 (inside)	Stainless steel 1.4305/AISI 303									113780
Straight-wire box for connector M12x1 with cable	5-pole	200 cm							(with temperature output)	114564
Corner-wire box for connector M12x1 with cable	5-pole	200 cm							(with temperature output)	114563
Straight-wire box for connector M12x1 screwing terminal	5-pole									115024
Clip for DN 8,10										112116
Clip for DN 15										110941
Clip for DN 20										112122
O-Ring for DN 8, 10	EPDM	ø 13.95 x 2.62							Copper tube and adapter	112124
O-Ring for DN 15	EPDM	ø 17.86 x 2.62							Copper tube and adapter	112265
O-Ring for DN 20	EPDM	ø 21.89 x 2.62							Copper tube and adapter	112723
O-Ring for DN 25	EPDM	ø 31 x 3							(as a replacement, already assembled)	112792
Connection copper tube for DN 8, 10		L=150 mm								112121
Connection copper tube for DN 15		L=150 mm								112211
Connection copper tube for DN 20		L=150 mm								112306
Adapter (inside thread) for DN 8, 10	Rp 3/8	Stainless steel 1.4305/AISI 303								112655
Adapter (inside thread) for DN 15	Rp 1/2	Stainless steel 1.4305/AISI 303								112660
Adapter (inside thread) for DN 20	Rp 3/4	Stainless steel 1.4305/AISI 303								112661

<sup>1)</sup> incl. 3xDi inlet and outlet side

<sup>2)</sup> Pv in Pa; Q in l/min

<sup>3)</sup> Connection set includes: 2x Clip, 2x Copper tubes or Adapter and 2x O-Ring

Dimension diagram DN 6, 8, 10, 15, 20, 25

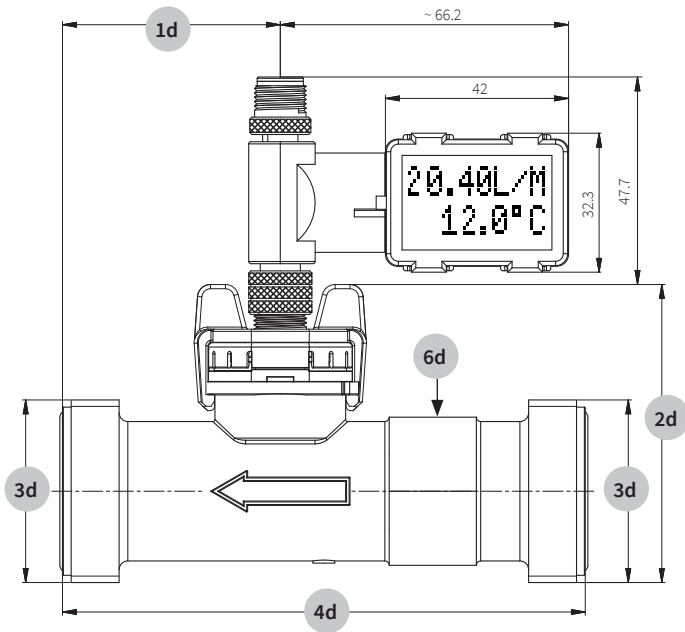

		1d	2d	3d	4d	5d	6d
DN6	K	43.7	53.0	G 1/2	77	11.5	12
DN6	G	48.2	55.7	G 3/4	86	11.5	12
DN8	K	43.7	53.0	G 1/2	77	11.5	12
DN8	G	48.2	55.7	G 3/4	86	11.5	12
DN10	K	35.0	51.3	G 1/2	81	11.5	19
DN10	G	39.5	54.1	G 3/4	90	11.5	19
DN15	K	36.6	56.1	G 3/4	87	16	22
DN15	G	41.6	59.5	G 1	97	16	22
DN20	K	36.6	61.5	G 1	105	20	27
DN20	G	42.6	65.8	G 1 1/4	117	20	27
DN25	K	50.0	68.3	G 1 1/4	120	26	34
DN25	G	56.0	71.3	G 1 1/2	132	26	34

Dimension diagram DN 8, 10, 15, 20

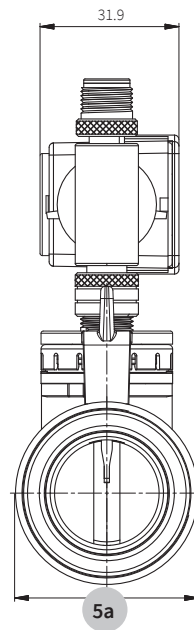
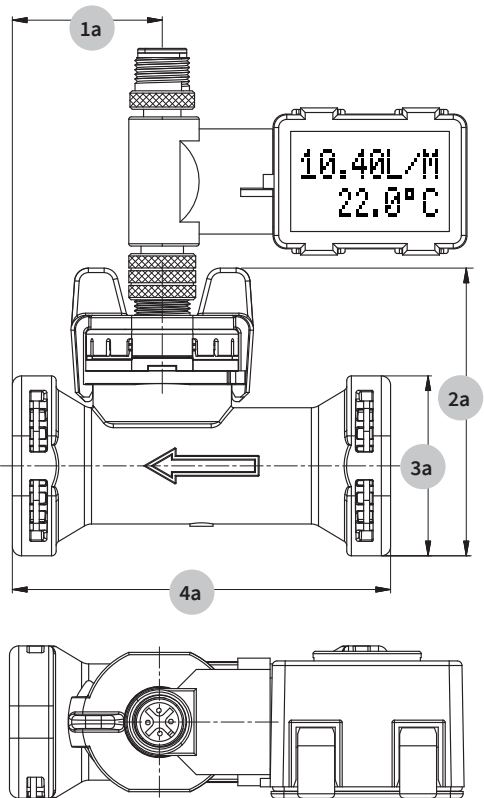

	1a	2a	3a	4a	5a
DN8	29.5	59.0	32.9	72	28.9
DN10	32.5	57.3	32.9	77	28.9
DN15	32.5	62.4	39.0	82	33.0
DN20	39.3	66.3	43.0	105	37.4

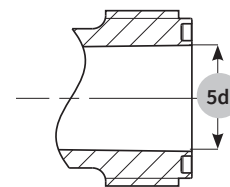

## Admissible locking torque



	DN6/8/10 G 1/2	DN6/8/10 G 3/4	DN15 G 3/4	DN15 G 1	DN20 G 1	DN20 G 1 1/4	DN25 G 1 1/4	DN25 G 1 1/2
M <sub>min</sub> [Nm]	1	1	1	2	2	2.5	2.5	2.5
M <sub>max</sub> [Nm]	12	12	12	12	12	15	15	15

## Accessories DN 8, 10, 15, 20

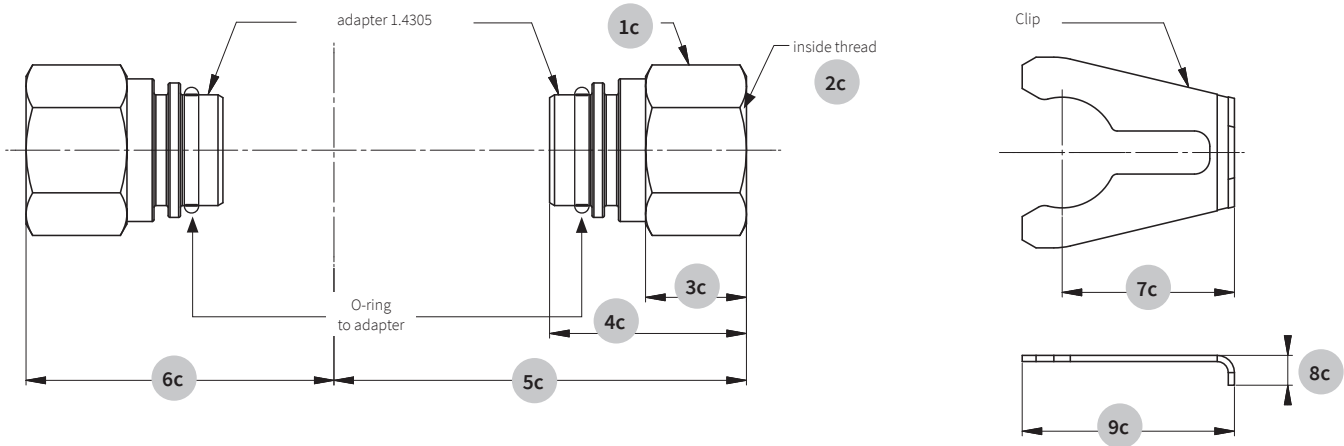

	1c	2c	3c	4c	5c	6c	7c	8c	9c
DN8	22	Rp 3/8 DIN 2999 Länge min. 9	14.0	29	57.65	44.65	24.5	7.3	30.8
DN10	22	Rp 3/8 DIN 2999 Länge min. 9	14.0	29	59.65	47.55	24.5	7.3	30.8
DN15	24	Rp 1/2 DIN 2999 Länge min. 11.5	16.4	32	67.05	50.05	28.0	7.6	34.5
DN20	30	Rp 3/4 DIN 2999 Länge min. 13	18.5	38	82.25	58.85	28.0	8.7	34.5

## Geometry of customers connection tube DN 8, 10, 15, 20

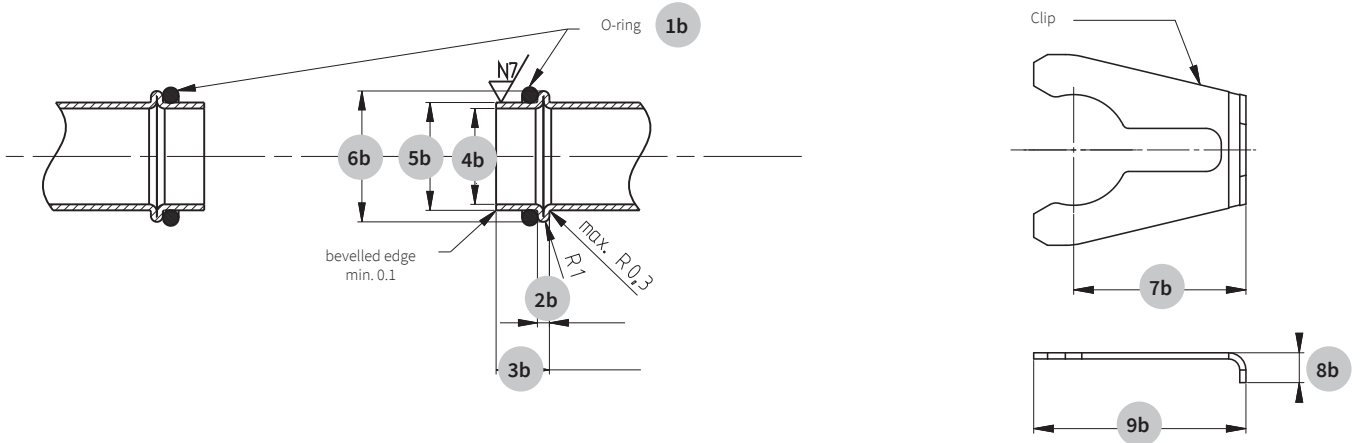

	1b	2b	3b	4b	5b	6b	7b	8b	9b
DN8	∅ 13.95x2.62	2 ± 0.2	8.9 ± 0.2	∅ 13 ± 0.2	∅ 15.00 ± 0.08	∅ 18.88 ± 0.1	24.5	7.3	30.8
DN10	∅ 13.95x2.62	2 ± 0.2	8.9 ± 0.2	∅ 13 ± 0.2	∅ 15.00 ± 0.08	∅ 18.88 ± 0.1	24.5	7.3	30.8
DN15	∅ 17.86x2.62	2 ± 0.2	8.9 ± 0.3	∅ 16 ± 0.2	∅ 18.00 <sup>+0.08</sup> <sub>-0.06</sub>	∅ 21.85 ± 0.1	28.0	7.6	34.5
DN20	∅ 21.89x2.62	2 ± 0.2	12.9 ± 0.3	∅ 20 ± 0.2	∅ 22.00 <sup>+0.08</sup> <sub>-0.06</sub>	∅ 25.85 ± 0.1	28.0	8.7	34.5

## Tube mounting instructions

Consider the following to ensure the correct function of the sensor.

- Only diameter changes from large to small are allowed.
- Avoid repeated elbows in the same level at entryside

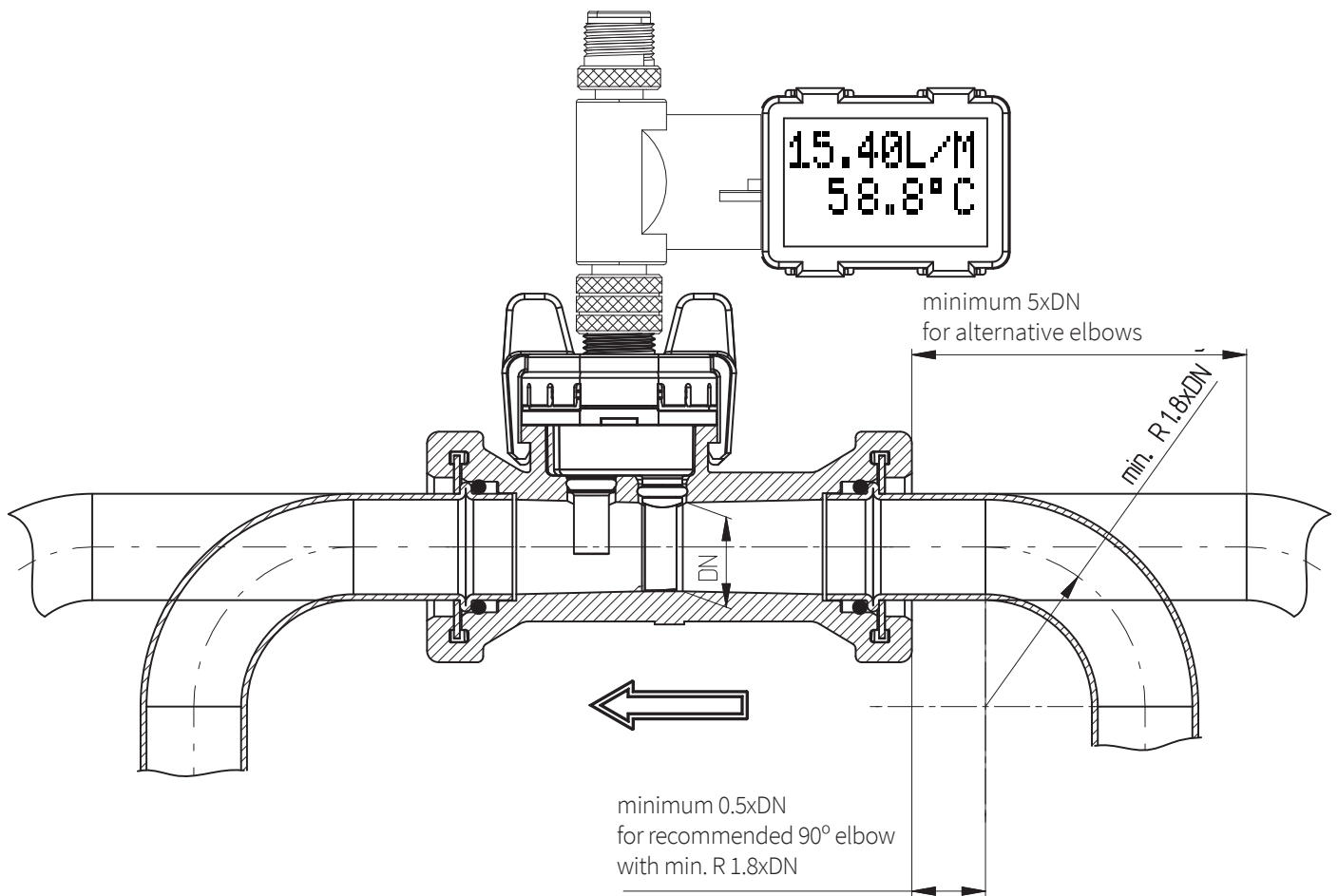

## Electrical connection

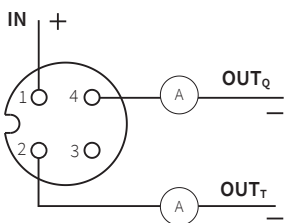

Pin 3 - not connected

Connect pin 1 and pin 4 to ensure the power supply of the internal electronic.

**Huba Control AG**

Headquarters Schweiz  
Industriestrasse 17  
CH-5436 Würenlos  
Telefon +41 56 436 82 00  
Fax +41 56 436 82 82  
info.ch@hubacontrol.com

**Huba Control AG**

Niederlassung Deutschland  
Schlattgrabenstrasse 24  
D-72141 Walddorfhäslach  
Telefon +49 7127 2393 00  
Fax +49 7127 2393 20  
info.de@hubacontrol.com

**Huba Control AG**

Vestiging Nederland  
Hamseweg 20A  
NL-3828 AD-Hoogland  
Telefoon +31 33 433 03 66  
Telefax +31 33 433 03 77  
info.nl@hubacontrol.com

**Huba Control SA**

Succursale France  
Rue Lavoisier  
Technopôle Forbach-Sud  
F-57602 Forbach Cedex  
Téléphone +33 3 87 84 73 00  
Télécopieur +33 3 87 84 73 01  
info.fr@hubacontrol.com

**Huba Control AG**

Branch Office United Kingdom  
Unit 13 Berkshire House, County Park  
Business Centre, Shivenham Road  
Swindon - Wiltshire SN1 2NR  
Phone +44 1993 77 66 67  
Fax +44 1993 77 66 71  
info.uk@hubacontrol.com

**[www.hubacontrol.com](http://www.hubacontrol.com)**