



Vortex flow sensor

## Flow sensor for liquid media

### Type 236

The type 236 is based on the type 210 but incorporates a brass housing. The Vortex Sensor type 236 has a rugged construction of brass connection. This flow sensor is available with a larger variety concerning power supply and outputs.

You can choose between various versions as integrated temperature measurement. With no moving parts the flow sensor is not sensitive to debris, has marginal pressure loss and high accuracy.



### Flow range

0.9 ... 240 l/min

### Nominal diameters

DN 8 / 10 / 15 / 20 / 25 / 32

### Temperature measurement

-40 ... +125 °C

- + Flow measuring with voltage, current, pulse or frequency output
- + Temperature non-sensitive measuring principle
- + Excellent media resistance (measuring element not in contact with the media)
- + Wide application temperature range
- + Marginal loss of pressure
- + Measuring element not sensitive to debris
- + Direct temperature measurement in the medium
- + Drinking water approval ACS, WRAS

## Technical Overview

### Flow measurement

Measuring principle	Vortex		Piezoelectric sensor element
Measuring range			0.9 ... 240 l/min
Nominal diameters			DN 8 / 10 / 15 / 20 / 25 / 32
Accuracy at < 50% fs (water)			< 1% fs
Accuracy at > 50% fs (water)			< 2% measuring value
Response time	Immediately. Therefore suitable for spigot use.	Frequency output (unfiltered)	Signal delay < 100 ms
			Response time < 5 ms
	Frequency output (filtered)    Analogue output		Signal delay < 2 s
			Response time < 500 ms

### Operating conditions

Medium	Suitable for heating circuit water with the usual additives Drinking water	other medium on request
Temperature	Media	< +125 °C
	Ambient	-15 ... +85 °C
	Ambient (2x 4 ... 20 mA)	-15 ... +65 °C
	Storage	-30 ... +85 °C
Max. pressure and medium temperature	(for lifetime)	12 bar at +40 °C
	(for lifetime)	6 bar at +100 °C
	(for 600 hours)	4 bar at +125 °C
	(for 2 hours)	4 bar at +140 °C
Cavitation	The following equation is valid to prevent cavitation:	$P_{\text{abs. outlet}} / P_{\text{difference}} > 5.5$
		(max. test pressure)

### Materials in contact with medium

Sensor paddle	ETFE
Case	Brass (CuZn40Pb2), PA6T/6I (40% GF)
Sealing material	EPDM (perox.) (for drinking water)
	FPM

### Electrical connection

Connector M12x1	Protection standard
	IP 65

Weight	with thread K	with thread M	with thread G
DN 8 with condensation protection	~ 160 g	-	~ 206 g
DN 10 with condensation protection	~ 200 g	~ 241 g	~ 307 g
DN 15 with condensation protection	~ 222 g	-	~ 288 g
DN 20 with condensation protection	~ 356 g	-	~ 469 g
DN 25 with condensation protection	~ 579 g	-	~ 681 g
DN 32 with condensation protection	~ 691 g	-	-

### Test / Admissions

Electromagnetic compatibility	CE conformity acc. EN 61326-2-3
Drinking water approval	WRAS
	ACS
	Plastic parts with KTW and W270 approval

### Packaging

Single packaging
Multiple packaging

## Minimum life span on high flow rate and high temperature

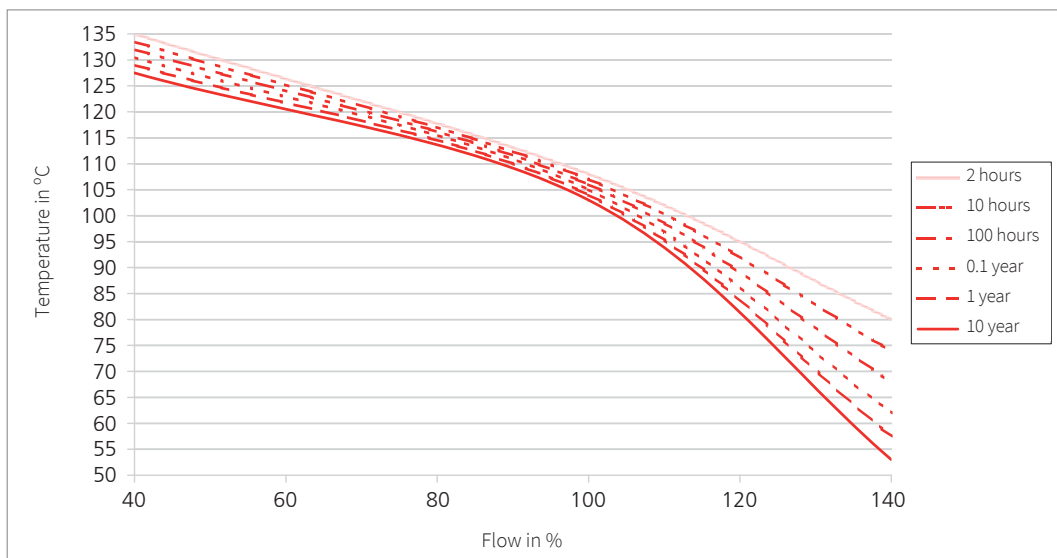

## Analogue output - Electrical overview

### Temperature measurement

Measuring principle	Resistance			PT1000
	Measuring range			-40 ... +125 °C
PT1000	Accuracy	class B DIN EN 60751	@ T = 0 °C @ T ≠ 0 °C	± 0.3 K ± 0.3 K ± 0.005 * ΔT
	Measuring range			-25 ... +125 °C
0 ... 10 V	Accuracy			± 0.5 K ± 0.005 * ΔT
	Calculation temperature			T (°C) = ±150 °C * U <sub>OUT,T</sub> - 25 °C 10 V
	Measuring range			-25 ... +125 °C
4 ... 20 mA	Accuracy			± 0.5 K ± 0.005 * ΔT
	Calculation temperature			T (°C) = I <sub>OUT,T</sub> - 4 mA * 150 °C - 25 °C 16 mA

Electronic	Voltage output	Current output	Dual power output
Power supply	11.5 ... 33 VDC	8 ... 33 VDC	10 ... 33 VDC
Output flow (Q)	analogue signal	0 ... 10 V	4 ... 20 mA
Output temperature (T)	signal	0 ... 10 V	4 ... 20 mA
Load against GND or IN	< 6 mA / < 100 nF <sup>1)</sup>	< (U <sub>IN</sub> - 8 V) / 20 mA	< (U <sub>IN</sub> - 10 V) / 20 mA
Current consumption load free (I <sub>IN</sub> )	< 5 mA	-	-
Electrical reliability	Short circuit, reverse voltage and external voltage protected within the admissible supply voltage.		

## Analogue output - Nominal diameters dependent variables

DN	Measuring range [l/min]	Flow range [m/s]	Pressure drop <sup>2),3)</sup>	K <sub>V</sub> [ $\frac{L}{V \cdot min}$ ]	K <sub>I</sub> [ $\frac{L}{mA \cdot min}$ ]
8	0.9 ... 15	0.133 ... 2.210	85.00 * Q <sup>2</sup>	1.5	0.938
10	1.8 ... 32	0.265 ... 4.716	22.50 * Q <sup>2</sup>	3.2	2.000
10	2.0 ... 40	0.295 ... 5.895	22.50 * Q <sup>2</sup>	4.0	2.500
15	3.5 ... 50	0.290 ... 4.145	6.70 * Q <sup>2</sup>	5.0	3.125
20	5.0 ... 85	0.265 ... 4.509	2.50 * Q <sup>2</sup>	8.5	5.313
25	9.0 ... 150	0.283 ... 4.709	0.92 * Q <sup>2</sup>	15.0	9.375
32	14 ... 240	0.290 ... 4.974	0.25 * Q <sup>2</sup>	24.0	15.000

### Characteristic line formula current output

$$Q_V = K_I * (I_{OUT} - 4 \text{ mA})$$

### Characteristic line formula voltage output

$$Q_V = K_V * U_{OUT}$$

### Legend

Q <sub>V</sub>	Volume flow rate	[l/min]
K <sub>V</sub>	Coefficient voltage output	[(l/min) / V]
K <sub>I</sub>	Coefficient current output	[(l/min) / mA]
U <sub>OUT</sub>	Voltage	[V]
I <sub>OUT</sub>	Current	[mA]

			1	2	3	4	5	6	7
<b>Analogue output - Order code selection table</b>			236. X X X X X X X						
<b>Version</b>	Flow		9			3,4	4		
	Flow and temperature (PT1000)		8			3,4	5		
	Flow and temperature (2x 0 ... 10 V)		6			3	5		
	Flow and temperature (2x 4 ... 20 mA)		5			5	5		
<b>Nominal diameters and flow range</b>	DN 8	0.9 ... 15 l/min.		0	8				K,G
	DN 10	1.8 ... 32 l/min.		1	0				
	DN 10	2.0 ... 40 l/min.		1	1				
	DN 15	3.5 ... 50 l/min.		1	5				K,G
	DN 20	5.0 ... 85 l/min.		2	0				K,G
	DN 25	9.0 ... 150 l/min.		2	5				K,G
	DN 32	14.0 ... 240 l/min.		3	2				K
<b>Output / power supply</b>	Analogue output 0 ... 10 V	11.5 ... 33 VDC	9,8,6			3			
	Analogue output 4 ... 20 mA	8 ... 33 VDC	9,8			4			
	Analogue output 4 ... 20 mA	10 ... 33 VDC	5			5			
<b>Electrical connection</b>	Connector M12x1	3-pole (with condensation protection)	9			3,4	4		
		5-pole (with condensation protection)	8,6,5				5		
<b>Sealing material</b>	EPDM	Ethylene propylene rubber (peroxidically cross-linked)							1
	FPM <sup>4)</sup>	Fluoro elastomer							2
<b>Tube connection</b>		K (DN 8, 10 - G ½; DN 15 - G ¾; DN 20 - G 1; DN 25 - G 1 ¼; DN 32 - G 1 ½)							K
		M (DN 10 - G ¾)							M
		G (DN 8 - G ¾; DN 10 - G 1; DN 15 - G 1; DN 20 - G 1 ¼; DN 25 - G 1 ½)							G

<sup>1)</sup> against GND only

<sup>2)</sup> incl. 3 x Di inlet and outlet side

<sup>3)</sup> Pv in Pa; Q in l/min

<sup>4)</sup> No drinking water approval

## Frequency output (filtered) and pulse output - Electrical overview

### Temperature measurement

Measuring principle	Resistance	PT1000 class B DIN EN 60751		
	Measuring range	-40 ... +125 °C		
PT1000	Accuracy	Class B DIN EN 60751	@ T = 0 °C	± 0.3 K
			@ T ≠ 0 °C	± 0.3 K ± 0.005 * ΔT
Temperature influences	Self-heating at temperature sensor		1 K/mW	
	Conduction resistance to connector		0.8 Ω	

### Electronic

Power Supply	4.75 ... 33 VDC			
Output flow (Q)	Level height (open collector)	< 0.5 ... > U <sub>in</sub> - 0.5 V		
Output temperature (T)	Resistant signal	PT1000 class B DIN EN 60751		
Load against GND or IN	> 1 kΩ / < 10 kΩ			
Current consumption load free (I <sub>m</sub> )	< 3 mA			
Electrical reliability	Short circuit, reverse voltage and external voltage protected within the admissible supply voltage.			

## Frequency output (filtered) and pulse output - Nominal diameters dependent variables

DN	Measuring range [l/min]	Flow range [m/s]	Pressure drop <sup>1),2)</sup>	K <sub>ff</sub> [(l/min) / Hz] at 0 ... 1000 Hz	Quantity per pulse K <sub>i</sub> [ml] (pulse)	Pulse (pulse output) [1/l]
8	0.9 ... 15	0.133 ... 2.210	85.00 * Q <sup>2</sup>	0.015	0.20	5000
10	1.8 ... 32	0.265 ... 4.716	22.50 * Q <sup>2</sup>	0.032	0.50	2000
10	2.0 ... 40	0.295 ... 5.895	22.50 * Q <sup>2</sup>	0.04	0.50	2000
15	3.5 ... 50	0.290 ... 4.145	6.70 * Q <sup>2</sup>	0.05	1.00	1000
20	5.0 ... 85	0.265 ... 4.509	2.50 * Q <sup>2</sup>	0.085	1.00	1000
25	9.0 ... 150	0.283 ... 4.709	0.92 * Q <sup>2</sup>	0.15	1.25	800
32	14 ... 240	0.290 ... 4.974	0.25 * Q <sup>2</sup>	0.24	2.00	500

### Characteristic line formula frequency output filtered (0 ... 1000 Hz, other frequency on request)

$$Q_v = K_{ff} * f$$

### Pulse

$$l/min = \frac{pulse}{s} * K_i * \frac{60}{1000}$$

### Legend

Q <sub>v</sub>	Volume flow rate	[l/min]
K <sub>ff</sub>	Coefficient frequency output filtered	[(l/min) / f]
f	Frequency	[Hz]

## Frequency output (filtered) and pulse output - Order code selection table

236. X X X X X X X

			1	2	3	4	5	6	7
Version	Flow		9				4		
	Flow and temperature (PT1000)		8				5		
Nominal diameters and flow range	DN 8	0.9 ... 15 l/min.		0	8				K,G
	DN 10	1.8 ... 32 l/min.		1	0				
	DN 10	2.0 ... 40 l/min.		1	1				
	DN 15	3.5 ... 50 l/min.		1	5				K,G
	DN 20	5.0 ... 85 l/min.		2	0				K,G
	DN 25	9.0 ... 150 l/min.		2	5				K,G
	DN 32	14.0 ... 240 l/min.		3	2				K
Output / power supply	Frequency output (filtered)	4.75 ... 33 VDC					6		
	Pulse output	4.75 ... 33 VDC					7		
Electrical connection	Connector M12x1	3-pole (with condensation protection)	9				4		
		5-pole (with condensation protection)	8				5		
Sealing material	EPDM	Ethylene propylene rubber (peroxidically cross-linked)							1
	FPM <sup>3)</sup>	Fluoro elastomer							2
Tube connection	Brass with outside thread	K (DN 8, 10 - G ½; DN 15 - G ¾; DN 20 - G 1; DN 25 - G 1 ¼; DN 32 - G 1 ½)							K
		M (DN 10 - G ¾)							M
		G (DN 8 - G ¾; DN 10 - G 1; DN 15 - G 1; DN 20 - G 1 ¼; DN 25 - G 1 ½)							

<sup>1)</sup> incl. 3x Di inlet and outlet side

<sup>2)</sup> Pv in Pa; Q in l/min

<sup>3)</sup> No drinking water approval

## Frequency output (unfiltered) - Electrical overview

### Temperature measurement

Measuring principle	Resistance	PT1000 class B DIN EN 60751		
	Measuring range	-40 ... +125 °C		
PT1000	Accuracy	Class B DIN EN 60751	@ T = 0 °C @ T ≠ 0 °C	± 0.3 K ± 0.3 K ± 0.005 * ΔT
Temperature influences	Self-heating at temperature sensor	1 K/mW		
	Conduction resistance to connector	0.8 Ω		

### Electronic

Power Supply	4.75 ... 33 VDC		
Output flow (Q)	Level height (push-pull)	< 0.5 ... > U <sub>N</sub> - 0.5 V	
Output temperature (T)	Resistant signal	PT1000 class B DIN EN 60751	
Load against GND or IN	< 1 mA / < 100 nF		
Current consumption load free (I <sub>N</sub> )	< 2 mA		
Electrical reliability	Short circuit, reverse voltage and external voltage protected within the admissible supply voltage.		

## Frequency output (unfiltered) - Nominal diameters dependent variables

DN	Tube connection	Measuring range [l/min]	Flow range [m/s]	Pressure drop <sup>1),2)</sup>	Quantity per pulse @50% fs [ml]	Frequency range unfiltered [Hz]	Q <sub>0</sub> [l/min]	K <sub>f</sub> [(l/min) / f]
8	K,G	0.9 ... 15	0.133 ... 2.210	85.00 * Q <sup>2</sup>	0.578	31 ... 427	-0.2	0.0356
10	K	1.8 ... 32	0.265 ... 4.716	22.50 * Q <sup>2</sup>	1.416	23 ... 374	-0.2	0.0860
	G,M				1.386	24 ... 380		0.0847
10	K	2.0 ... 40	0.295 ... 5.895	22.50 * Q <sup>2</sup>	1.419	26 ... 467	-0.2	0.0860
	G,M				1.386	26 ... 479		0.0840
15	K	3.5 ... 50	0.290 ... 4.145	6.70 * Q <sup>2</sup>	3.036	20 ... 273	-0.2	0.1836
	G				2.993	20 ... 277		0.1810
20	K	5.0 ... 85	0.265 ... 4.509	2.50 * Q <sup>2</sup>	6.173	14 ... 229	-0.3	0.3730
	G				6.140	14 ... 230		0.3710
25	K	9.0 ... 150	0.283 ... 4.709	0.92 * Q <sup>2</sup>	12.201	13 ... 205	-0.2	0.7340
	G				12.134	13 ... 206		0.7300
32	K	14 ... 240	0.290 ... 4.974	0.25 * Q <sup>2</sup>	27.513	9 ... 145	-1.47	1.6710

### Characteristic line formula frequency output unfiltered

$$Q_v = K_f * f + Q_0$$

### Formula quantity per pulse [litres/pulse]

$$\text{Quantity per Pulse} = \frac{K_f * Q_v}{60 * (Q_v - Q_0)}$$

### Legend

Q <sub>v</sub>	Volume flow rate	[l/min]
Q <sub>0</sub>	Axis intercept	[l/min]
K <sub>f</sub>	Coefficient frequency output	[(l/min) / f]
f	Frequency	[Hz]
Quantity per Pulse	Quantity per pulse	litres / pulse

## Frequency output (unfiltered) - Order code selection table

			1	2	3	4	5	6	7
			236. X X X X X X X						
Version	Flow		9				4		
	Flow and temperature (PT1000)		8				5		
Nominal diameters and flow range	DN 8	0.9 ... 15 l/min.		0	8				K,G
	DN 10	1.8 ... 32 l/min.		1	0				
	DN 10	2.0 ... 40 l/min.		1	1				
	DN 15	3.5 ... 50 l/min.		1	5				K,G
	DN 20	5.0 ... 85 l/min.		2	0				K,G
	DN 25	9.0 ... 150 l/min.		2	5				K,G
	DN 32	14.0 ... 240 l/min.		3	2				K
Output / power supply	Frequency output (unfiltered)	4.75 ... 33 VDC				2			
Electrical connection	Connector M12x1	2- or 3-pole (condensation protection)	9				4		
		4- or 5-pole (condensation protection)	8,6				5		
Sealing material	EPDM	Ethylene propylene rubber (peroxidically cross-linked)						1	
	FPM <sup>3)</sup>	Fluoro elastomer						2	
Tube connection	Brass with outside thread	K (DN 8, 10 - G ½; DN 15 - G ¾; DN 20 - G 1; DN 25 - G 1 ¼; DN 32 - G 1 ½)							K
		M (DN 10 - G ¾)							M
		G (DN 8 - G ¾; DN 10 - G 1; DN 15 - G 1; DN 20 - G 1 ¼; DN 25 - G 1 ½)							

<sup>1)</sup> incl. 3x Di inlet and outlet side

<sup>2)</sup> Pv in Pa; Q in l/min

<sup>3)</sup> No drinking water approval

## Accessories *(Accessories supplied loose)*

## Order number

Straight-wire box for connector M12x1 with cable	3-pole	200 cm	114605
Corner-wire box for connector M12x1 with cable	3-pole	200 cm	114604
Straight-wire box for connector M12x1 with cable	5-pole	200 cm (with temperature)	114564
Corner-wire box for connector M12x1 with cable	5-pole	200 cm (with temperature)	114563
Straight-wire box for connector M12x1 screwing terminal	5-pole		115024

## Dimension diagram

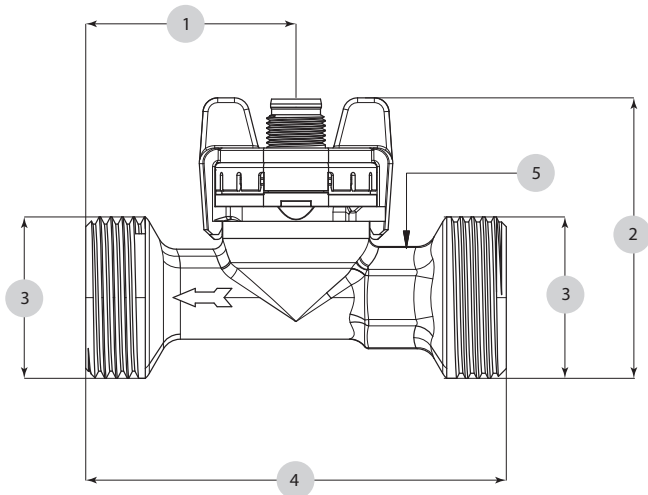

	1	2	3	4	5
DN 8 K	33.3	52.9	G ½	77	↻ 15
DN 8 G	33.3	55.7	G ¾	77	↻ 15
DN10 K	43	51.1	G ½	86	↻ 19
DN 10 M	43	54.1	G ¾	86	↻ 19
DN 10 G	43	57.3	G 1	86	↻ 19
DN 15 K	41	55.9	G ¾	87	↻ 22
DN 15 G	41	59.3	G 1	87	↻ 22
DN 20 K	40.6	61.3	G 1	105	↻ 27
DN 20 G	40.6	65.6	G 1 ¼	105	↻ 27
DN 25 K	50	68.1	G 1 ¼	120	↻ 34
DN 25 G	50	71.1	G 1 ½	120	↻ 34
DN 32 K	50	74.9	G 1 ½	134	↻ 41

## Tube mounting instructions

Consider the following to ensure the correct function of the sensor.

- Only diameter changes from large to small are allowed.
- Avoid repeated elbows in the same level at entrieside

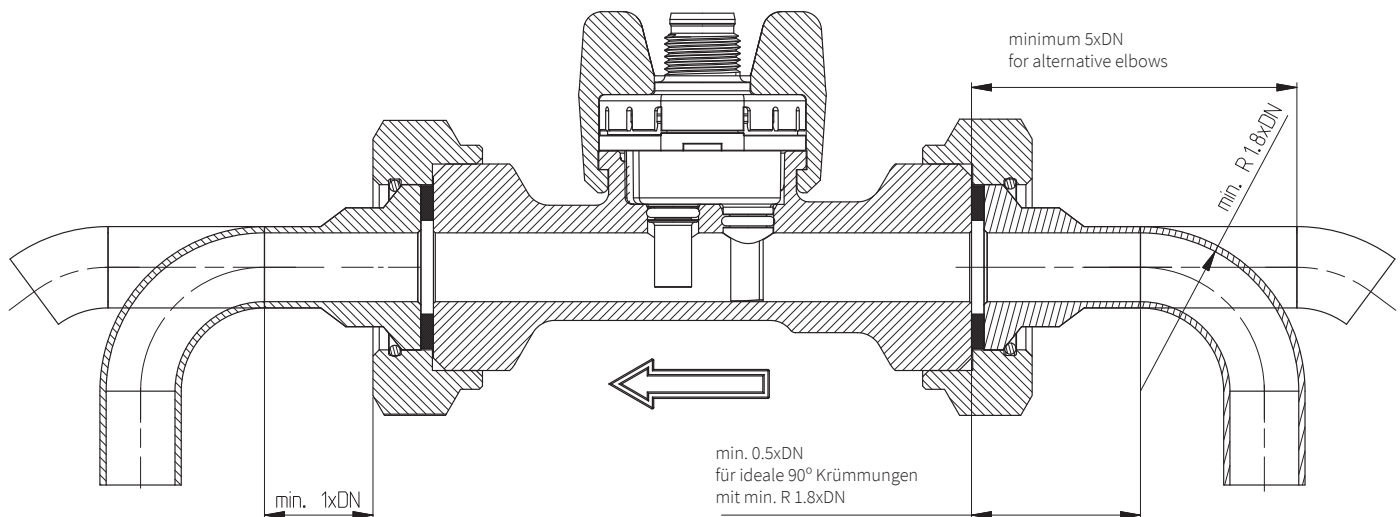

## Electrical connection

Connector M12x1 without temperature measurement

1

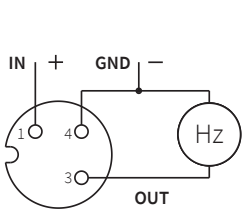

Frequency output unfiltered

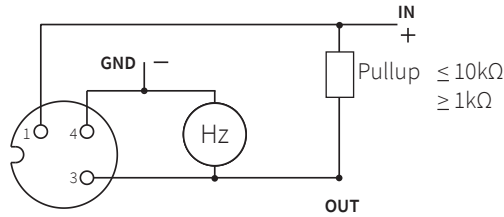

Frequency output filtered  
Pulse output

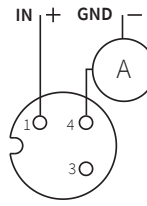

Current output

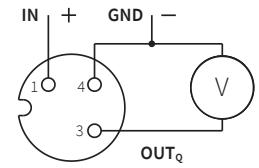

Voltage output

Connector M12x1 with temperature measurement

2

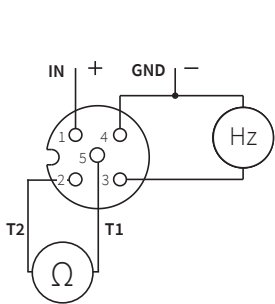

frequency output with temperature measurement  
PT1000

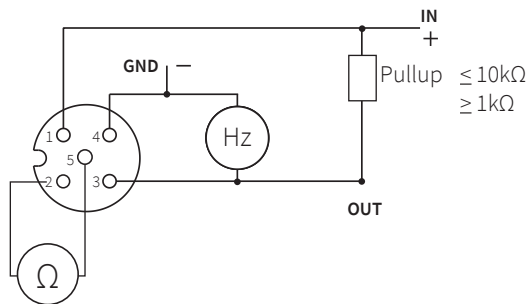

Frequency output filtered  
Pulse output

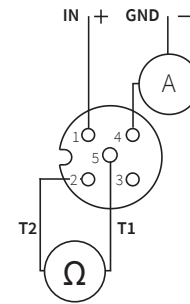

Current output with temperature measurement  
PT1000

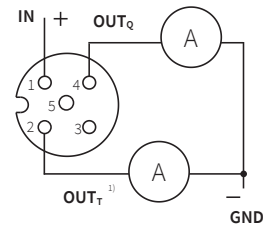

Current output with temperature measurement  
4 ... 20 mA

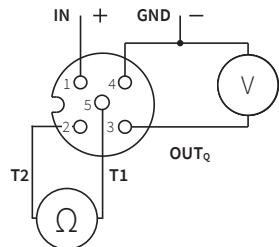

Voltage output with temperature measurement  
PT1000

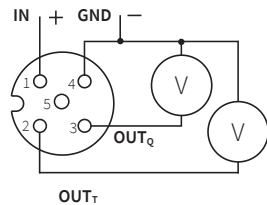

Voltage output with temperature measurement  
0 ... 10 V

Pin	Colour
1	brown
3	blue
4	black
1	brown
2	white
3	blue
4	black
5	gray

<sup>1)</sup> «OUT T» is only in operation if «OUT Q» is connected

## Influence of glycol

With the following definitions we are able to correct the influence of media with higher viscosity than water (= media viscosity > 1.8 cSt) in order to reach a measuring accuracy of 3% fs in the range of 1.8 - 4 cSt and of 4% in the range of 4 - 14 cSt ( $\nu$  = viscosity in cSt).

### Definition of viscosity of glycol-water-compound

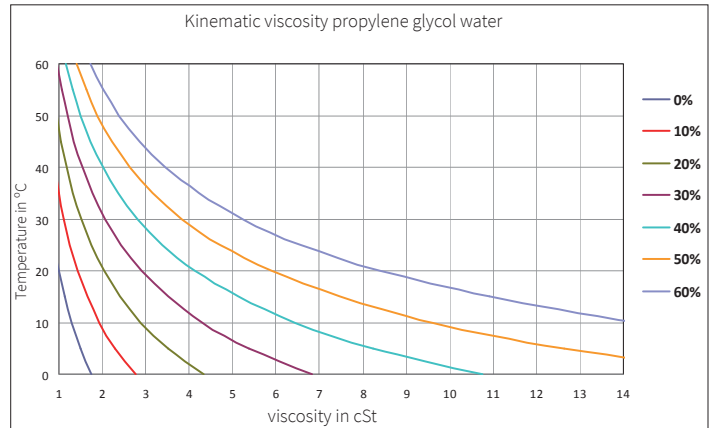
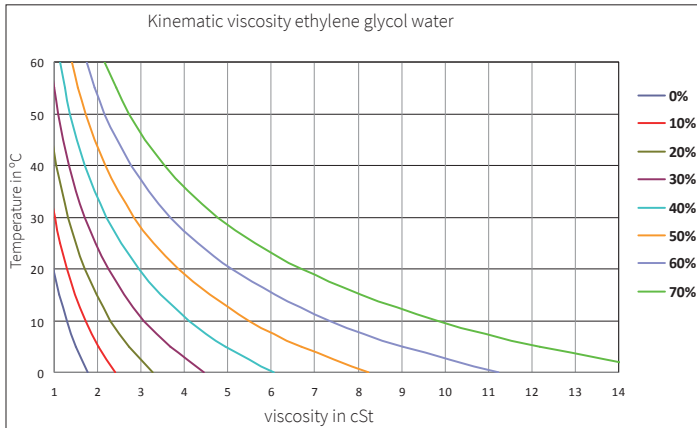

### Definition of respond threshold $Q_{min}$

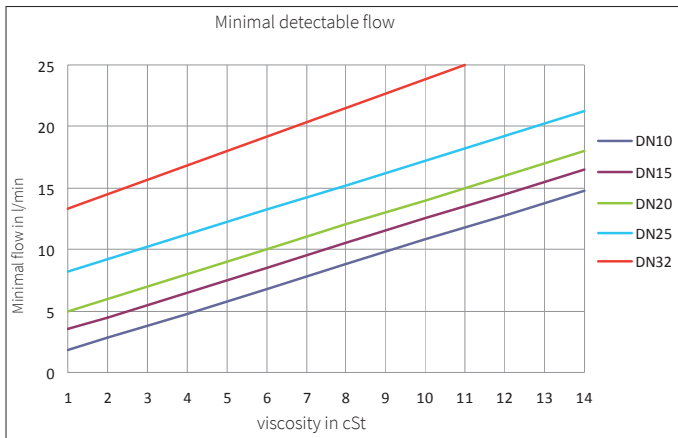

### Definition of characteristic line formula $Q_v = k_f * f + Q_0$

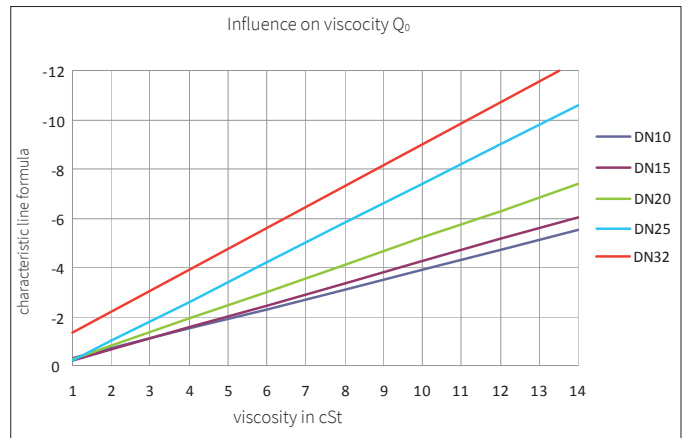

#### Formula respond threshold $Q_{min}$ in l/min

< DN 10 not possible

DN10:	$Q_{min} = \nu + 0.8$
DN15:	$Q_{min} = \nu + 2.5$
DN20:	$Q_{min} = \nu + 4.0$
DN25:	$Q_{min} = \nu + 8.0$
DN32:	$Q_{min} = \nu + 13.0$

#### Formula characteristic line for $Q \geq Q_{min}$ in l/min

< DN 10 not possible

Frequency output (unfiltered):

DN10:	$Q = K_f * f - 0.40\nu + 0.20$
DN15:	$Q = K_f * f - 0.45\nu + 0.25$
DN20:	$Q = K_f * f - 0.55\nu + 0.25$
DN25:	$Q = K_f * f - 0.80\nu + 0.60$
DN32:	$Q = K_f * f - 0.85\nu + 0.55$

Frequency output (filtered):

DN10:	$Q = 0.032 * f - 0.40\nu + 0.40$
DN15:	$Q = 0.050 * f - 0.45\nu + 0.45$
DN20:	$Q = 0.080 * f - 0.55\nu + 0.55$
DN25:	$Q = 0.150 * f - 0.80\nu + 0.80$
DN32:	$Q = 0.240 * f - 0.85\nu + 0.55$

Impulse output:

DN10:	$Q = 0.030 * \#Pulse/s - 0.40\nu + 0.40$
DN15:	$Q = 0.060 * \#Pulse/s - 0.45\nu + 0.45$
DN20:	$Q = 0.060 * \#Pulse/s - 0.55\nu + 0.55$
DN25:	$Q = 0.075 * \#Pulse/s - 0.80\nu + 0.80$
DN32:	$Q = 0.120 * \#Pulse/s - 0.85\nu + 0.55$

Voltage output 0 ...10 V:

DN10:	$Q = 3.2 * U_{Out} - 0.40\nu + 0.40$
DN15:	$Q = 5.0 * U_{Out} - 0.45\nu + 0.45$
DN20:	$Q = 8.5 * U_{Out} - 0.55\nu + 0.55$
DN25:	$Q = 15.0 * U_{Out} - 0.80\nu + 0.80$
DN32:	$Q = 24.0 * U_{Out} - 0.80\nu + 0.80$

Current output 4 ... 20 mA (I in mA):

DN10:	$Q = 2.000 * (I - 4 \text{ mA}) - 0.40\nu + 0.40$
DN15:	$Q = 3.125 * (I - 4 \text{ mA}) - 0.45\nu + 0.45$
DN20:	$Q = 5.313 * (I - 4 \text{ mA}) - 0.55\nu + 0.55$
DN25:	$Q = 9.375 * (I - 4 \text{ mA}) - 0.80\nu + 0.80$
DN32:	$Q = 15.000 * (I - 4 \text{ mA}) - 0.80\nu + 0.80$



**Huba Control AG**

Headquarters Schweiz  
Industriestrasse 17  
CH-5436 Würenlos  
Telefon +41 56 436 82 00  
Fax +41 56 436 82 82  
info.ch@hubacontrol.com

**Huba Control AG**

Niederlassung Deutschland  
Schlattgrabenstrasse 24  
D-72141 Walddorfhäslach  
Telefon +49 7127 2393 00  
Fax +49 7127 2393 20  
info.de@hubacontrol.com

**Huba Control AG**

Vestiging Nederland  
Hamseweg 20A  
NL-3828 AD-Hoogland  
Telefoon +31 33 433 03 66  
Telefax +31 33 433 03 77  
info.nl@hubacontrol.com

**Huba Control SA**

Succursale France  
Rue Lavoisier  
Technopôle Forbach-Sud  
F-57602 Forbach Cedex  
Téléphone +33 3 87 84 73 00  
Télécopieur +33 3 87 84 73 01  
info.fr@hubacontrol.com

**Huba Control AG**

Branch Office United Kingdom  
Unit 13 Berkshire House, County Park  
Business Centre, Shrivenham Road  
Swindon Wiltshire SN1 2NR  
Phone +44 1993 77 66 67  
Fax +44 1993 77 66 71  
info.uk@hubacontrol.com

**[www.hubacontrol.com](http://www.hubacontrol.com)**