

- For limit level sensing of liquid, and bulk-solid and powder materials
- Universal using (bulk solids, liquids, aggressive materials, petroleum products etc.)
- Direct mounting into various containers, silos, vessels, tanks, filling inlets, reservoirs, etc.
- Sensitivity and hysteresis fluently adjustable
- Output types NPN, PNP, NAMUR



Capacitive level sensors DLS® are designed for limit sensing of the level of liquid and bulk solids in tanks, sumps, tubes or, hoppers, silos, etc. The sensors are manufactured in several modifications of sensing electrodes (rod and rope). The electrodes can be given an insulating coating, a useful feature in case of adhesive, aggressive or conductive media sensing. Rod electrodes are also available in a version with reference tube for measuring fluids in tanks made from non-conductive material.

Sensors are manufactured in the following configurations: **N** – for non-explosive areas, **Xd** – For use in flammable dust atmospheres; **Xi** – Explosion proof – intrinsically safe for hazardous (explosive) areas and **XiM** – Explosion proof – intrinsically safe for use in mines with methane or flammable dust presence danger (see technical specifications). There are high temperature performance **NT, XiT, XiMT** available and various types of process connection (metric and pipe thread, jointless connection Tri-clamp).

VARIANTS OF SENSORS

- **DLS-27_-10** **Uncoated short bar electrode** for sensing non-adhesive bulk solids (sand, sugar) and non-conductive liquids (petroleum products, oils), horizontal mounting.
Electrode length 50 mm or 100 mm.
- **DLS-27_-11** **Fully coated short bar electrode**, for sensing conductive liquids (water). Horizontal mounting into tanks and tubes.
Electrode length 30 mm.
- **DLS-27_-20** **Semi-coated rod electrode** for sensing slightly adhesive bulk solids (cement, flour) and non-conductive liquids (plant oils), horizontal, slant or vertical mounting.
Electrode length from 0.1 m to 1 m.
- **DLS-27_-21** **Fully coated rod electrode (FEP insulation)** for sensing conductive liquids (water solutions, water), adhesive and aggressive materials, horizontal or vertical mounting.
Electrode length from 0.1 m to 1 m.
- **DLS-27_-22** **Fully coated rod electrode (PFA insulation) with enhanced resistance**, for sensing aggressive conductive liquids and materials. Horizontal or vertical mounting.
Electrode length from 0,1 m ... 1 m.
- **DLS-27_-30** **Dismountable uncoated rod electrode** for sensing bulk solids and conductive or non-conductive liquids. Vertical or horizontal slant mounting.
Electrode length 0.1 m ... 3 m.
- **DLS-27_-31** **Fully coated rod electrode**, for sensing aggressive conductive liquids (water, various chemicals). Vertical mounting.
Electrode length from 0.1 m to 2 m.
- **DLS-27_-40** **Uncoated rope electrode and weight**, for general purpose use in deeper silos (bulk solids sensing – sand, gravel, cement) or sumps (sensing liquids). Vertical mounting.
Electrode length from 1 m to 6 m.

DIMENSIONAL DRAWING

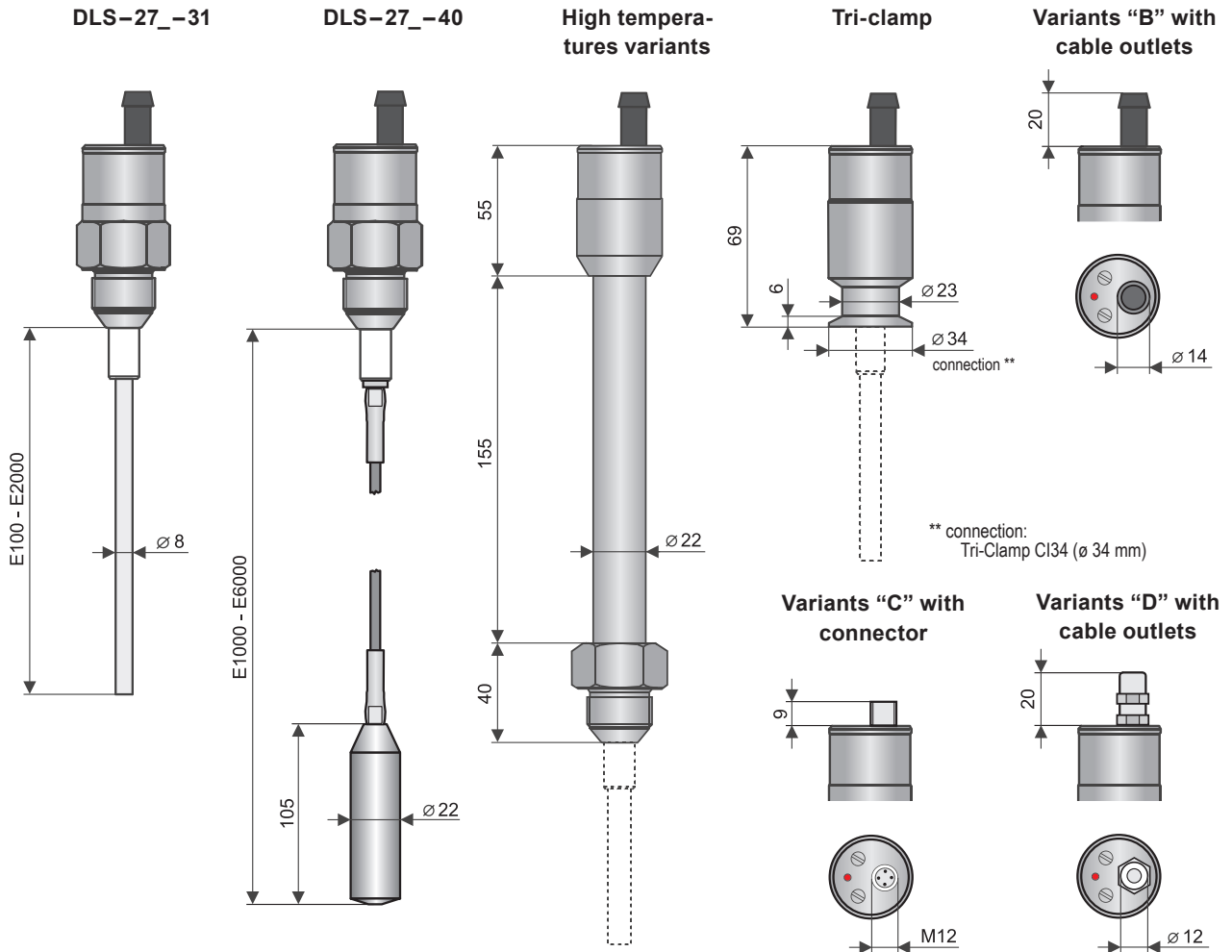
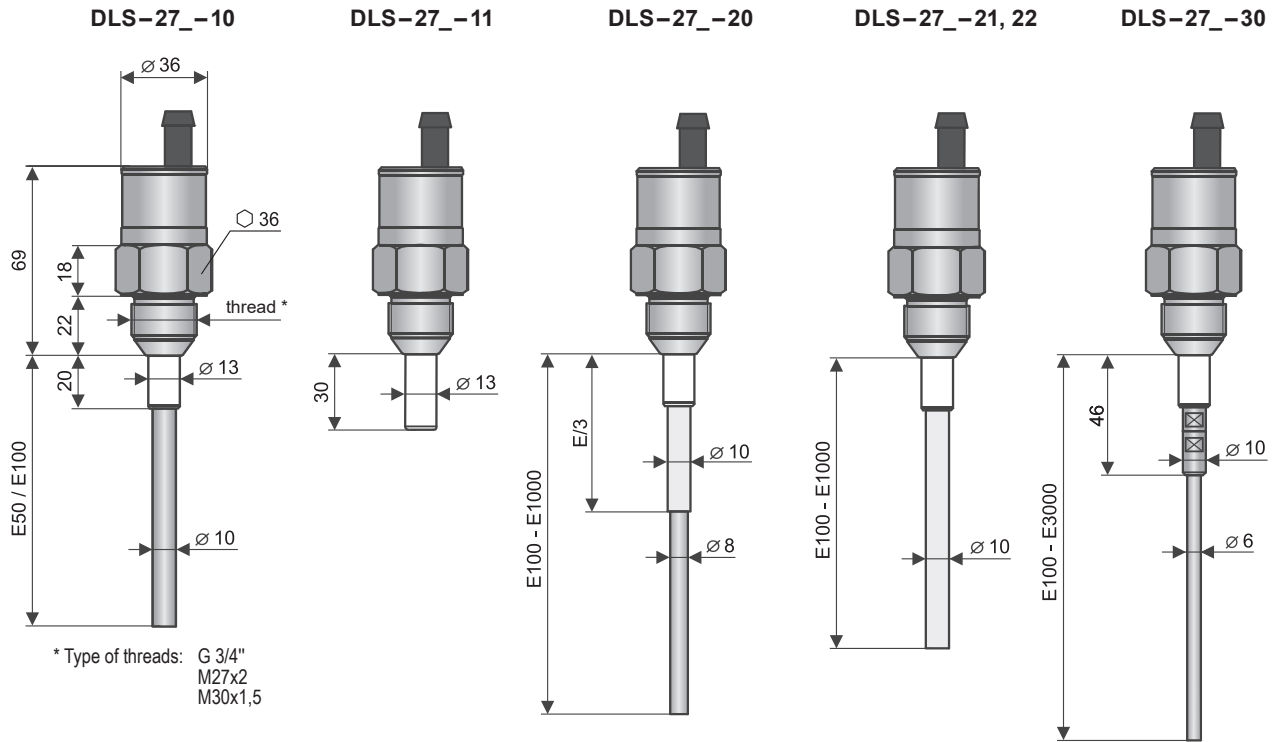

TECHNICAL SPECIFICATIONS

TECHNICAL DATA		
Supply voltage	performance DLS-27N performance DLS-27Xd	7 ... 36 V DC 7 ... 33 V DC
Current supply (state OFF / ON)		3 / 10 mA *
Max. switching current (NPN, PNP)	performance DLS-27N performance DLS-27Xd	200 mA 200 mA
Residual voltage – ON state		max. 1,5 V
Delay of output signal due to electrode activation		0,2 s
Input resistance / Electric strength		1 MΩ / 1 kV AC
Coupling capacity / Electric strength		47 nF / 250 V AC *
Protection class		IP 67
Cable (version with cable outlets)		PVC 3 x 0,5 mm ² or 2 x 0,75 mm ²
Weight (excl. electrode, cable 2 m)	DLS-27_ DLS-27_T	cca 0,4 kg cca 0,7 kg

* Only for variants "N" and "Xd"

ELECTRICAL PARAMETERS – variants Xi, XiT, XiM, XiMT	
Supply voltage	8 ... 9 V DC
Current supply (state OFF / ON) – NAMUR	≤ 1 mA / ≥ 2,2 mA
Limit parameters	Ui = 12 VDC; li = 15 mA; Pi = 45 mW; Ci = 15 nF; Li = 10 μH
Coupling capacity / Electric strength	2,7 nF / 500 V AC
Reference value LC for the parameters of the used cable	typ. C < 150 pF/m typ. L < 0,8 μH / m

USED MATERIALS		
Part of the DLS	Type	Standard material *
Housing	All type expect Tri-Clamp Tri-Clamp	W.Nr. 1.4301 (AISI 304) W.Nr. 1.4404 (AISI 316 L)
Insulating bushing	All type	PTFE
Electrode	DLS-27_-10,11,20,21,22,30,31 DLS-27_-40	W.Nr. 1.4404 (AISI 316 L) W.Nr. 1.4401 (AISI 316)
Electrode coating	DLS-27_-11 DLS-27N-20, 21, 31 DLS-27Xi-21, 31 DLS-27Xd(Xi, XiT) -20 DLS-27_-22	PTFE FEP FEP Electrostatically conductive PTFE Ex PFA
Weight	DLS-27_-40	W.Nr. 1.4301 (AISI 304)

* It is always necessary to verify the chemical compatibility of the material with the measured medium. You can also choose another type of material after agreement.

PROCESS CONNECTION		
Type	Size	Marking
Pipe thread	G 3/4"	G
Metric thread	M27x2	M27
Metric thread	M30x1,5	M30
Jointless connection (Tri-Clamp) (DN 20)	ø 34 mm	CI34

TYPE OF OUTPUT	
Output	Variants
NPN (NC; NO)	N, NT, Xd
PNP (PC; PO)	N, NT, Xd
NAMUR (RC; RO)	Xi, XiM, XiT, XiMT

WORKING AREAS (EN 60079-0, EN 60079-10-1(2))	
DLS-27N	Basic performance for non-explosive atmospheres.
DLS-27NT	High-temperature basic performance for non-explosive atmospheres.
DLS-27Xd (10, 20, 30, 40)	Performance is protected by "Ex t" lock with intrinsically safe electrical circuit „ia" for hazardous areas (flammable dust areas) Ⓜ II 1/2 D Ex ia/tb [ia] IIIC T78°C Da/Db, electrode part zone 20, housing with electronics zone 21 see Fig. 20. The type 20 has electrode coating from electrostatically conductive PTFE Ex.
DLS-27Xi (10, 20, 30, 40)	Intrinsically safe explosion-proof performance for use in hazardous areas (explosive gas atmospheres or explosive atmospheres with dust) Ⓜ II 1 G Ex ia IIB T6 Ga; Ⓜ II 1 D Ex ia IIIC T76°C Da with intrinsically safe supply units, electrode part zone 0 and 20. Only Type 10, 20, 30, 40. The type 20 has electrode coating from electrostatically conductive PTFE Ex.
DLS-27Xi (11, 21, 22, 31)	Intrinsically safe explosion-proof performance for use in hazardous areas (explosive gas atmospheres) Ⓜ II 1 G Ex ia IIB T6 Ga with intrinsically safe supply units, whole sensor zone 0.
DLS-27XiT (10, 20, 30, 40)	Intrinsically safe high-temperature explosion-proof performance for use in hazardous areas (explosive gas atmospheres or explosive atmospheres with dust) Ⓜ II 1/2 G Ex ia IIB T6 Ga/Gb; Ⓜ II 1/2 D Ex ia IIIC T76°C Da/Db with intrinsically safe supply units, electrode part zone 0 and 20, housing zone 1 and 21, see Fig. 20. The type 20 has electrode coating from electrostatically conductive PTFE Ex.
DLS-27XiT (11, 21, 22, 31)	Intrinsically safe high-temperature explosion-proof performance for use in hazardous areas (explosive gas atmospheres) Ⓜ II 1/2 G Ex ia IIB T6 Ga/Gb with intrinsically safe supply units, electrode part zone 0, housing zone 1 see Fig. 20.
DLS-27XiM	Intrinsically safe explosion-proof performance for use in mines with the occurrence of methane or coal dust Ⓜ I M2 Ex ia I Mb with intrinsically safe supply units.
DLS-27XiMT	Intrinsically safe high-temperature explosion-proof performance for use in mines with the occurrence of methane or coal dust Ⓜ I M2 Ex ia I Mb with intrinsically safe supply units.

TEMPERATURE AND PRESSURE RESISTIVITY								
variant	temperature tm	temperature tp	temperature ta	max. operating pressure for temperature tp				
				Up to 30°C	Up to 85°C	Up to 120°C	Up to 150°C	Up to 180°C
DLS-27N-10, 11	-40°C ... +100°C	-25°C ... +85°C	-20°C ... +80°C	3 MPa	2 MPa	–	–	–
DLS-27N-20, 30	-40°C ... +300°C	-25°C ... +85°C	-20°C ... +80°C	3 MPa	2 MPa	–	–	–
DLS-27N-21, 22, 31, 40	-40°C ... +200°C	-25°C ... +85°C	-20°C ... +80°C	3 MPa	2 MPa	–	–	–
DLS-27NT-10, 11, 21, 22, 31, 40	-40°C ... +200°C	-40°C ... +200°C	-20°C ... +80°C	3 MPa	2 MPa	0,5 MPa	0,3 MPa	0,1 MPa
DLS-27NT-20, 30	-40°C ... +300°C	-40°C ... +200°C	-20°C ... +80°C	3 MPa	2 MPa	0,5 MPa	0,3 MPa	0,1 MPa
DLS-27Xd	-20 ... +70°C	-20 ... +70°C	-20 ... +70°C	3 MPa	2 MPa	–	–	–
DLS-27Xi, XiM	-20°C ... +85°C	-25°C ... +85°C	-20°C ... +75°C	3 MPa	2 MPa	–	–	–
DLS-27XiT, XiMT-10, 11, 20, 30	-30°C ... +200°C	-40°C ... +200°C	-20°C ... +75°C	3 MPa	2 MPa	0,5 MPa	0,3 MPa	0,1 MPa
DLS-27XiT, XiMT-21, 22, 31, 40	-30°C ... +120°C	-40°C ... +180°C	-20°C ... +75°C	3 MPa	2 MPa	0,5 MPa	0,3 MPa	0,1 MPa
DLS-27Xi, XiT, XiM, XiMT – zone 0	-20 ... +60°C	-20 ... +60°C	-20 ... +60°C	0,08... 0,11 MPa up to 60°C				
DLS-27XiM (XiMT) - mine application Mb	Max. 150°C any surface where the coal-dust may consist layer							

Note: For the correct operation of the level meter, none of the here provided temperature ranges may be exceeded (tp, tm or ta).
1) The here-mentioned temperatures are visually explain in Fig.

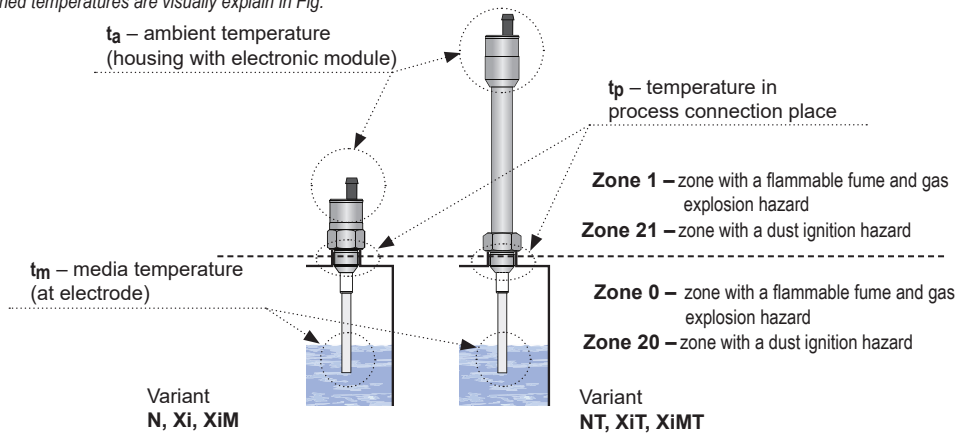

Illustration of areas for temperature measurement and explosive zones

ELECTRIAL CONNECTION

Sensor with NPN or PNP output is allowed to lead only by resistive or inductive lead. Positive supply voltage (+U) is connected to the brown conductor BN (1), negative (0V) to the blue conductor BU (3) and the leads (only NPN or PNP type of output) to the black conductor BK (4). The capacity loads and low resistance loads (bulb) is evaluated by the sensor as short circuit.

Version Xd is manufacture only with fixing cable (variants "D" with cable outlets). The end of this cable must be in terminal box with protection class IP6x.

For "B" and "D" variants with the fixed cable, the individual colour cores of the connecting cable are connected to the respective terminals of the related equipment (supply unit) see Fig. 14 to 16.

For "C" variant with the connector, the cable can be supplied with the sensor (length 2 or 5 m), fitted with the pressed connector socket or dismountable connector socket without the cable (see accessories), the connector is not part of the sensor. In this case the cable is connected to the inside pins of the socket according to Fig. 17.

The sensor with related equipment is interconnected by a suitable three-core (N and Xd variations) or two-core (Xi, XiT, XiM, XiMT variations) cable. The length of the cable for the Xi, XiT, XiM, XiMT variations must be selected with respect to the maximum permitted parameters (usually inductance and capacity) of the outside intrinsically safe circuit of supply units (NSSU, NDSU, NLCU).

If using a dismountable connector socket, the outside diameter of the cable is a maximum of 6 mm.

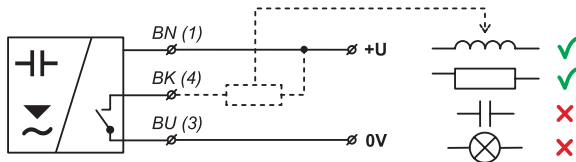

Fig. 1: NPN output type sensor connection (configuration N, NT, Xd)

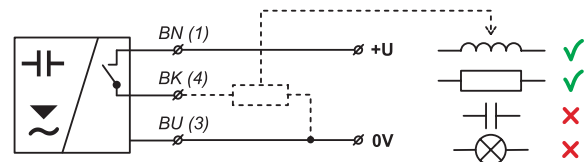

Fig. 2: PNP output type sensor connection (configuration N, NT, Xd)

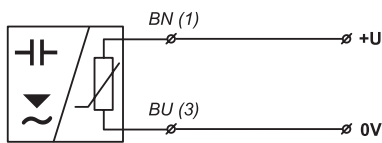

Fig. 3: Connection of a sensor with a NAMUR type output (configuration Xi, XiM, XiT, XiMT)

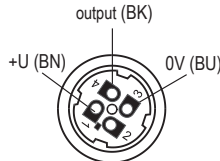

Fig. 4: Inside of the connector socket

Legend:
(1,...) – numbers of terminals inside the connector socket
BK – Black
BN – Brown
BU – Blue

RANGE OF APPLICATION AND INSTALLATION OF INDIVIDUAL VARIANTS

DLS-27 -10

Produced in two versions – with 50 mm or 100 mm electrode. The shorter version (E50) is suitable for clean non-conductive liquids level sensing (oils, diesel, petrol, etc.). The longer version (E100) is designed for non-adhesive bulk solids or non-adhesive powder materials (plastic granulates, sand, sugar, grains, detergents, etc.) and other slightly impure, non-conductive liquids (lubricants, plant oils). The sensor is specified to be mounted directly into a vessel or storage tank wall (best by horizontal position) by means of welding flanges or stainless steel fixing nuts. In case of level sensing of low-permittivity media in non-metal storage tanks, we recommend mounting the sensor on an auxiliary metal-plate electrode with min. area of 200 cm².

DLS-27 -11

Specified for level sensing of conductive liquids (water and water solutions). It can be used to identify the boundary between fluids with differing permittivity (e.g. water – oil). The sensor is mounted directly into the side wall of the vessel or in a pipe (horizontal position) by means of a standard steel or stainless steel welding flange.

DLS-27 -20

Designed for limit level detection of bulk solids with low specific weight and permittivity (cement, hydrated lime, flour), and for materials expected to have changing properties (fly ash, sawdust, feed mixtures, etc.). It is possible to use it for sensing non-conductive liquids containing a small amount of water (up to 2%) or other impurities (plant oils, liquid propane, etc.). The sensor is mounted directly into the wall of a vessel or storage tank using steel welding flanges or fixing nuts horizontally, slanted from the side or vertically. It is recommended to mount a sensor with an electrode longer than 300 mm only in the vertical position. Hollow spaces should be minimized between the electrode and the wall where the sensed material can accumulate (see application notes). In non-metal storage tanks, we recommend mounting the sensor on an auxiliary metal-plate electrode with min. area of 400 cm².

DLS-27 -21, 22

Specified for conductive liquids level sensing (water, water solutions, mud, etc.). It reacts to partial or full immersion of the electrode (depending on the adjusted sensitivity). The lower the sensitivity, the higher the sensor's resistance to contaminants and clinging remnants of material. The sensor with electrode length of up to 200mm can be desensitized to complete water immersion, so it can be operated in the horizontal position. The sensor can be operated in the vertical position with any length up to 1m. The sensor is

mounted directly into the wall of the tank in horizontal or vertical position by applying a steel or stainless steel welding flange. For variant "22", the material PFA is used to insulate the electrode.

DLS-27 -30

Designed for sensing conductive and non-conductive liquids and bulk solids. It is not recommended to install the sensor into closed vessels (storage tanks) where intensive water vapour condensation occurs. The sensor reacts to electrically conductive liquids just by touch of the end of electrode. To react to a non-conductive liquid (bulk solid), it is necessary to have 5 ± 20% immersion of the electrode according to the sensor's adjusted sensitivity and permittivity of the sensed material. The sensor is mounted directly into a tank, hopper or sump in slant or vertical position by means of welding flange or stainless steel fixing nut. In non-metal storage tanks, we recommend mounting the sensor on an auxiliary metal-plate electrode with min. area of 500 cm².

DLS-27 -31

Designed for limit level detection of conductive liquids (water and solutions of various chemicals). It is possible to place the sensor electrode into closed vessels (storage tanks), open canals and sumps. The sensor reacts to the conductive fluid level after 2 ± 20% immersion of the electrode based on the sensor's set sensitivity. The sensor is mounted vertically directly into a vessel, tank or open (concrete, plastic) sumps by means of welding flanges or fixing nuts. When installing the sensor into open sumps, it is necessary to secure conductive connection of the sensor housing with the sensed liquid. It is possible to use a metal structure, armouring or another auxiliary electrode. If you must sense an aggressive medium in a closed plastic container, contact the manufacturer.

DLS-27 -40

For sensing conductive and non-conductive liquids and bulk solids at greater depths (sewerage sumps, shafts, wells, cement storage tanks, sand, gravel, etc.). It is not appropriate to place the sensor electrode into closed containers (storage tanks) where intensive condensation of water vapour occurs. The sensor reacts to electrically conductive liquids just by touch of the end of electrode. To react to non-conductive liquid or bulk solid, a 5 ± 20% immersion into the material is necessary based on the sensitivity set on the sensor and the permittivity of the sensed material. The sensor is mounted vertically directly into the wall of a storage tank or sump. For open (concrete) sumps, it can be mounted on an auxiliary metal structure conductively connected with the sensed material. For mounting, you can use supplied welding flanges or fixing nuts.

SETTINGS

The sensor is factory adjusted for basic sensitivity. The sensitivity is set by trimmer located under the left cover screw on the rear side. Clockwise turning makes the sensitivity lower, reverse direction turning makes the sensitivity higher. The hysteresis is set by trimmer located under the right cover screw. Clockwise turning makes the hysteresis higher, reverse direction turning makes it lower. The lower the hysteresis is, the higher sensitivity is possible to obtain, but the resistance against various disturbances get worse.

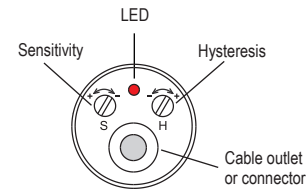

Top view of level sensor

For detailed information please read at the instructions manual.

FUNCTION AND STATUS INDICATION

	Level state	Type of output	Output state	LED
Minimum level sensing		DLS-27N _ _ _ _ -NO_ _ DLS-27Xd _ _ _ -D-NO_ _ DLS-27N _ _ _ _ -PO_ _ DLS-27Xd _ _ _ -D-PO_ _	CLOSED	(Shine)
		DLS-27Xi _ _ _ -RO_ _	HIGHER CURRENT	
		DLS-27N _ _ _ _ -NO_ _ DLS-27Xd _ _ _ -D-NO_ _ DLS-27N _ _ _ _ -PO_ _ DLS-27Xd _ _ _ -D-PO_ _	OPEN	(Dark)
		DLS-27Xi _ _ _ -RO_ _	LOWER CURRENT	
Maximum level sensing		DLS-27N _ _ _ _ -NC_ _ DLS-27Xd _ _ _ -D-NC_ _ DLS-27N _ _ _ _ -PC_ _ DLS-27Xd _ _ _ -D-PC_ _	CLOSED	(Shine)
		DLS-27Xi _ _ _ -RC_ _	HIGHER CURRENT	
		DLS-27N _ _ _ _ -NC_ _ DLS-27Xd _ _ _ -D-NC_ _ DLS-27N _ _ _ _ -PC_ _ DLS-27Xd _ _ _ -D-PC_ _	OPEN	(Dark)
		DLS-27Xi _ _ _ -RC_ _	LOWER CURRENT	

ORDER CODE

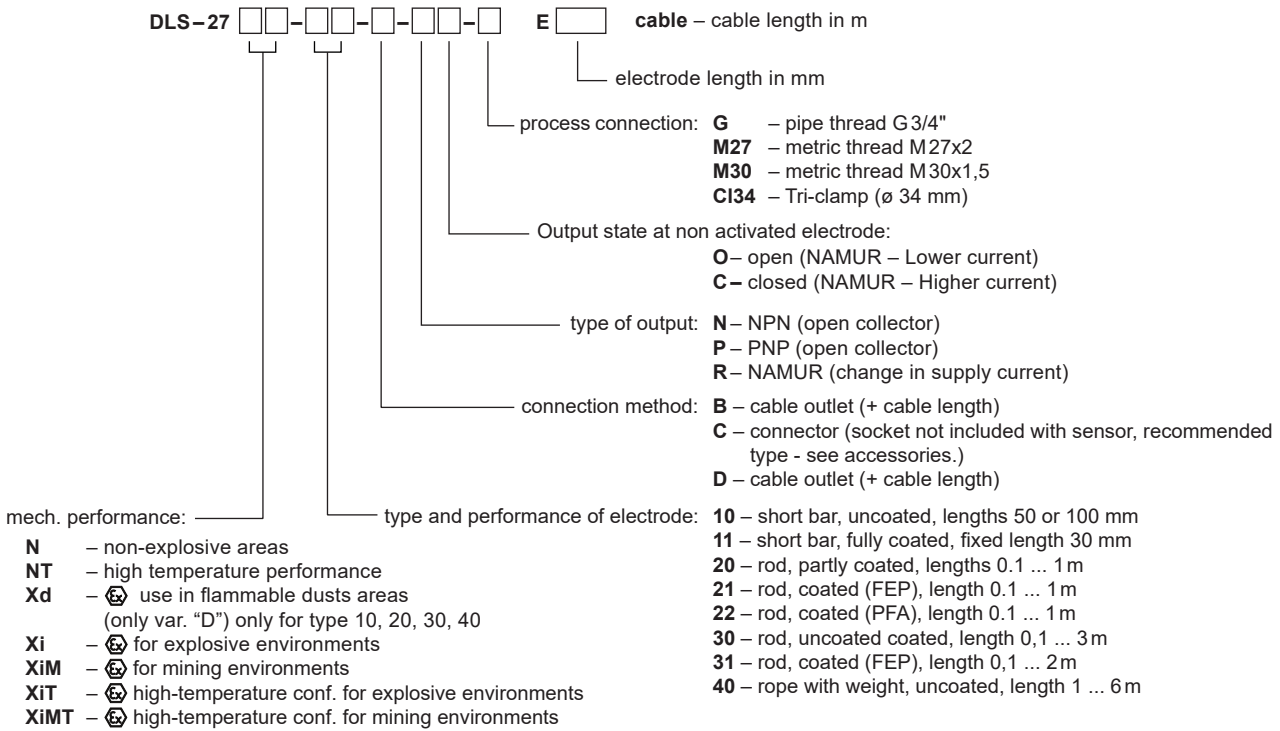

CORRECT SPECIFICATION EXAMPLES

DLS-27N-10-B-NO-M27 E100 cable 5 m

(N) Normal performance; (10) Uncoated bar electrode; (B) Cable outlet with 5 m length cable; (NO) Output type NPN with open state at non-activated electrode; (M27) Metric thread M27x2 process connection; (E100) Electrode length 100 mm

DLS-27NT-21-C-PC-G E580

(NT) High temperature performance; (21) Fully coated rod electrode (FEP); (C) Connector; (PC) Output type NPN with closed state at non-activated electrode; (G) Pipe thread G3/4" process connection; (E580) Electrode length 580 mm.

DLS-27Xi-30-C-RO-M30 E1420

(Xi) Explosion-proof performance; (30) Dismountable uncoated electrode; (C) Connector, (RO) Output type NAMUR with lower current at non-activated electrode, (M30) Metric thread M30x1.5 process connection; (E1420) Electrode length 1420 mm.

DLS-27Xd-20-D-NC-G E430 cable 3 m

(Xd) Flammable dust areas performance; (20) Partly coated electrode; (D) Cable outlet; (NC) Output type PNP with closed state at non-activated electrode; (M30) Metric thread M30x1,5 process connection; (E430) Electrode length 430 mm.

ACCESSORIES

standard - included in the level sensor price

- 1 pcs. Seal (asbestos free) *
- 1 pcs. Screwdriver for adjustment (each 5 pcs.)

optional – for a surcharge - (see catalogue sheet of accessories)

- Extra cables (over the standard length 2 m)
- Connector socket (type ELWIKa or ELKA)
- Normal steel welding flange ON-27x2
- Stainless steel welding flange NN-G3/4"
- Stainless steel fixing nut UM-27x2
- Other seals (PTFE, AI, etc.)
- Auxiliary plate electrode PDE-27

* Pressure resistance - see the table in the accessories datasheet in the "seals and gaskets".

SAFETY, PROTECTIONS, COMPATIBILITY AND EXPLOSION PROOF

The level sensor is equipped with protection against electric shock on the electrode, reverse polarity, output current overload, short circuit and against current overload on output.

Protection against dangerous contact is provided by low safety voltage according to EN 33 2000- 4- 41. Electromagnetic compatibility is provided by conformity with standards EN 55022/B, EN 61326-1, EN 61000-4-2 to -6.

Explosion proof DLS–27Xi (XiT, XiM, XiMT) is provided by conformity with standards EN 60079-0:2013, EN 60079-11:2012.

Explosion proof DLS–27Xd is provided by conformity with standards EN 60079-0:2013, EN 60079-11:2012, EN 60079-31:2014. Explosion proof DLS–27Xd is verified FTZÚ – AO 210 Ostrava – Radvanice: FTZÚ 10 ATEX 0092X.

A declaration of conformity was issued for this device in the wording of Act No. 90/2016 Coll., as amended. Supplied electrical equipment matches the requirements of valid European directives for safety and electromagnetic compatibility.

Special conditions for safe use of variant DLS-27Xi (XiT, XiM, XiMT)

If the apparatus is used as device of Group II and with using of an approved power supply device, which output parameters comply with required input parameters, it is necessary to have an galvanic separation or in case of apparatus without galvanic separation (Zener barriers) it is necessary to provide equipotential equalizing between sensor and barrier earthing point.

If the apparatus is used in coal mine as device of Group I and with using of an approved power supply device, which output parameters comply with required input parameters it is necessary to have an galvanic separation.

When used in zone 0 the present explosive atmosphere of air mixture and gases, vapours of mists must be comply with: $20^{\circ}\text{C} \leq T_{\text{amb}} \leq 60^{\circ}\text{C}$, $0.8 \text{ bar} \leq p \leq 1.1 \text{ bar}$.

Design DLS–27Xi can be used in zone 0 or zone 20. With design DLS–27XiT can be used in zone 0 and zone 20 only electrode part head with electronics can be used only in zone 1 or zone 21.

Ambient temperature: $T_{\text{amb}} = -20^{\circ}\text{C}$ to $+75^{\circ}\text{C}$

Temperature of measured medium according to design variant see chapter “Specification”.

For design DLS–27XiMT it is necessary to observe that temperature of any surface of apparatus, when coal dust can from a layer, do not exceed 150°C .

Special conditions for safe use of variant DLS-27Xd

Ambient temperature: $T_{\text{amb}} = -20^{\circ}\text{C}$ to $+70^{\circ}\text{C}$

The sensor DLS-27Xd is designed with permanent cable. The cable must be terminated in connection box with degree of protection IP 6X.

The end of the sensor must be protected against direct daylight.

Maximum effective value of AC or DC voltage that can be applied to the terminals of device, which are not intrinsically safe, without breaking the type of protection is $U_{\text{m}} = 253 \text{ V}$.