

IEG-TC1+T

IEG-N1F+T

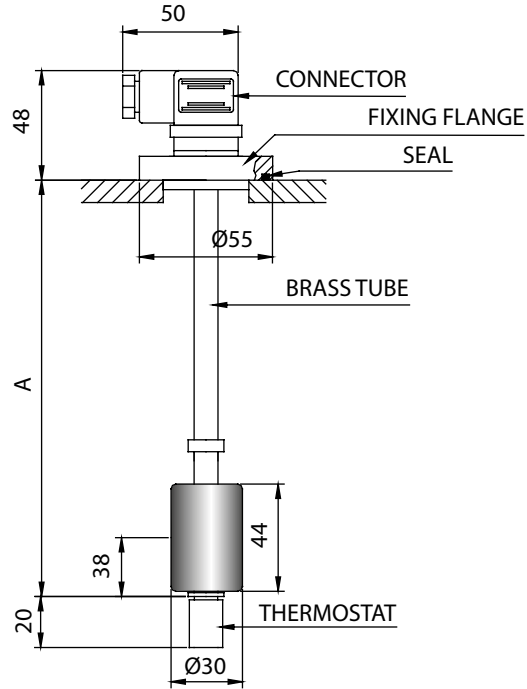

ELECTROMAGNETIC LEVEL INDICATORS WITH ELECTRIC CONTACT AND THERMOSTAT

USE:

Made to ensure the minimum or maximum level in tanks and hydraulic power packs and activation of the thermostat when, for operating reasons, the temperature must not exceed values harmful to correct operation.

LEVEL INDICATOR OPERATION:

When the float of the indicator encounters the Reed switch at the pre-established point, the contact activated by the magnet housed in the float opens or closes, thus obtaining the possibility of sending a luminous or acoustic signal or activating or disconnecting any electrical equipment connected to it.

THERMOSTAT OPERATION:

When the temperature of the liquid in the tank reaches the thermostat setting value, the thermostat closes or opens for switching on a lamp or interrupting operation of the machine connected to it, or activating any cooling equipment, thus preventing the risk of overheating and permanent damage.

IMPORTANT:

To invert the level signal from N.C. to N.O. and vice versa, just remove the bottom stop and turn the float upside down.

- 1= THERMOSTAT
 - 2= ELECTRIC LEVEL INDICATOR
 - 3= COMMON
 - 4= EARTH
- Connection:
Connector CE EN 175301-803-A
IP65 PG.9/11

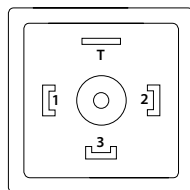

Connector CE
EN 175301-803-A
IP65 PG.9/11

| THERMOSTAT ELECTRICAL CHARACTERISTICS | |
|---------------------------------------|---|
| VOLTAGE | 250 V. COMMUTABLE |
| FREQUENCY | 50 Hz |
| LOAD VALUES | 4,0 A. cos φ = 0,6 (I M OT) 6,3 A. cos φ = 1,0 (I N) |
| MAX. LOAD | 10 A. cos φ = 1 |
| COMMUTATING TEMPERATURE | 50°C - 60°C - 70°C - 80°C |
| CONTACTS | N.C.H. = NORMALLY CLOSED N.A. = NORMALLY OPEN |
| TOLERANCES | ± 5°C |

| MODEL | PIPE MATERIAL | CONNECTION ALUMINUM | ELECTRICAL CONTACTS | ELECTRICAL CHARACTERISTICS | | | | | TEMPERATURE | | MAX. PRESSURE |
|---------------|---------------|---------------------|---------------------|----------------------------|--------------------------|--------------------------|--------------------|------------|-------------|--------------|---------------|
| | | | | POWER COMMUTABLE IN D.C. | POWER COMMUTABLE IN A.C. | CURRENT STRENGTH IN A.C. | COMMUTABLE VOLTAGE | PROTECTION | RANGE | TEFLON WIRES | |
| IEG - N1F + T | BRASS | | | 80 W | 80 V.A. | 1,3 A | 250 VDC 250 VAC | IP 65 | -20 +80 °C | -20 +120 °C | 10 Bar |
| IEG - TC1 + T | | 1" GAS | | | | | | | | | |